

110

1	4 ~ 6
9	11 12
14	16 ~ 20
64	74

Refer to the service manual for the grease application points.

# Extended Magazine for

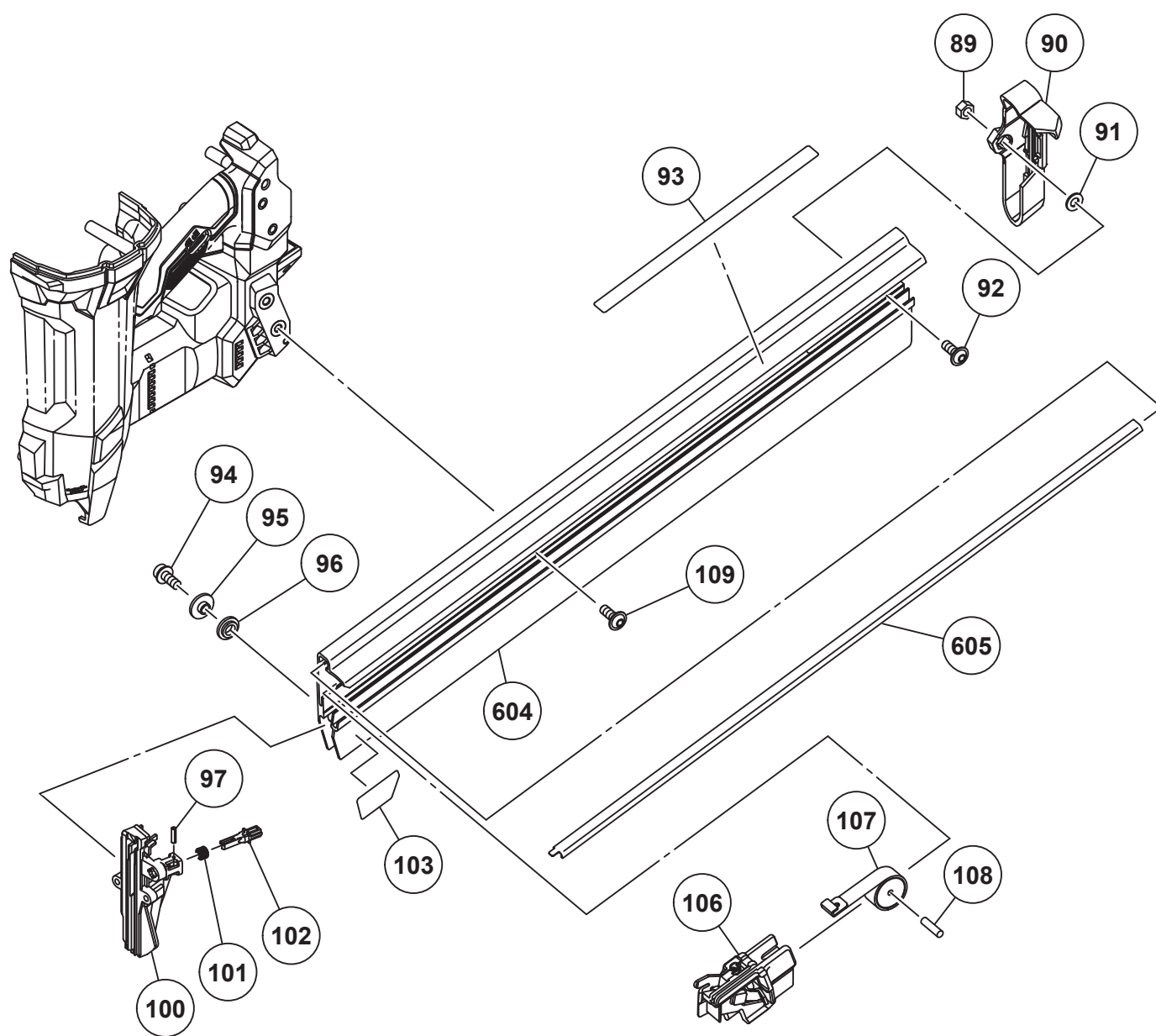

MODEL
NR1890DRA(2/3)

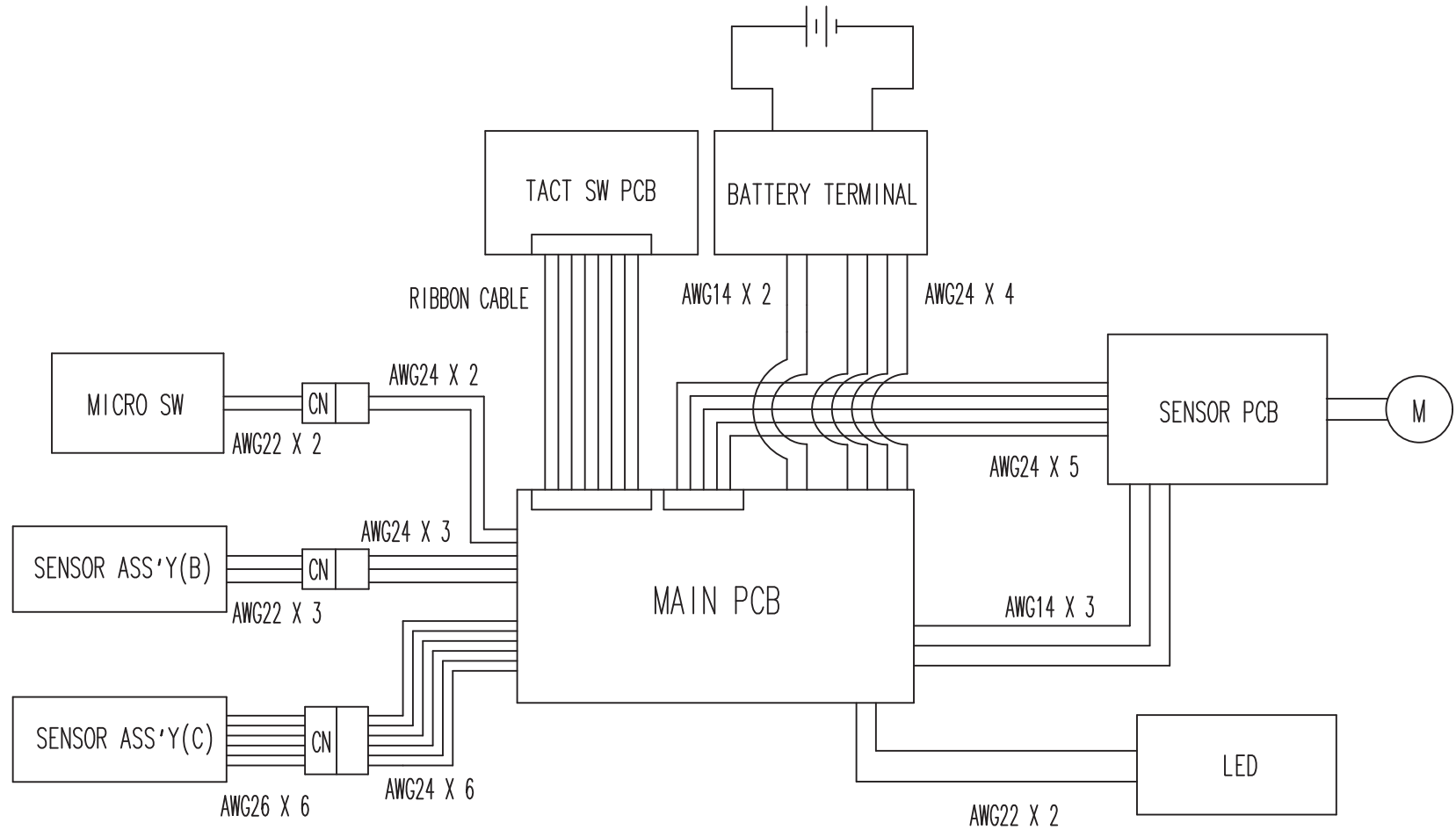

# HIKOKI

## CORDLESS NAILER NR1890DRA

Item No.	Code No.	Description	No. Used	Remarks
1	382121	CHARGE CAP COVER	1	
2	371015	HEX. SOCKET BOLT M5	4	
3	382715	TOP COVER	1	
4	382123	CHARGE CAP	1	
5	884112	O-RING (I.D 10.7)	1	
6	382124	VALVE CORE CUSHION	1	
7	382125	VALVE CORE	1	
8	382691	CHAMBER COVER	1	
9	382692	O-RING (I.D 49.5)	3	
10	382689	CYLINDER	1	
11	382693	O-RING (I.D 84.5)	1	
12	382694	O-RING (I.D 89.5)	1	
13	382690	CHAMBER BASE	1	
14	372338	NYLOCK BOLT M6	4	
15	382747	PISTON ASS'Y	1	INCLUD. 16-18
16	382725	SLIDE RING	2	
17	382383	X-RING	1	
18	382384	O-RING	1	
19	382382	PISTON BUMPER	1	
20	382714	RUBBER CUSHION (C)	1	
21	382686	NOSE	1	
22	372332	RETAINING RING D52	1	
23	382712	BB HOLDER	1	
24	6000VV	BALL BEARING 6000VVCMP2L	1	
25	372329	O-RING (I.D 20.22)	1	
26	382710	PIN WHEEL COVER	1	
27	382708	WHEEL SPRING (D)	1	
28	382704	WHEEL SPRING (A)	1	
29	372328	NEEDLE ROLLER D3	1	
30	382709	PIN (B)	1	
31	382703	PIN WHEEL	1	
32	382706	PIN (C)	1	
33	301684	O-RING (S-30)	2	
34	382705	WHEEL SPRING (B)	1	
35	382707	WHEEL SPRING (C)	1	
36	6902VV	BALL BEARING 6902VV	1	
37	372325	NEEDLE ROLLER D4	8	
38	382711	FELT (P)	1	
39	382735	PIN WHEEL ASS'Y	1	INCLUD. 24-38
40	382688	NYLOCK BOLT (W/FLANGE) M4X20	1	
41	382702	SENSOR (B)	1	
42	372311	NYLOCK BOLT (W/FLANGE) M4X14	2	
43	382728	TORX FLANGE BOLT M5X22	2	
44	372307	PUSHING LEVER SPRING (B)	1	
45	376289	SPECIAL BOLT M6	1	
46	382697	PUSHING LEVER (B)	1	
47	959148	STEEL BALL D3.175 (10 PCS.)	2	
48	372315	ADJUSTER SPRING	2	
49	382721	ADJUSTER	1	
50	382733	PUSHING LEVER (B) ASS'Y	1	INCLUD. 45-49
51	382696	PUSHING LEVER (A)	1	
52		NAME PLATE	1	
53	301653	TAPPING SCREW (W/FLANGE) D4X20 (BLACK)	18	

\* ALTERNATIVE PARTS

# HIKOKI

## CORDLESS NAILER NR1890DRA

Item No.	Code No.	Description	No. Used	Remarks
54	382727	TORX FLANGE BOLT M5X15	2	
55	382731	HOOK	1	
56	382713	BUMPER	2	
57	310124	HANDLE DAMPER	3	
58	382723	HOUSING (C).(D) SET	1	
*59	378683	BATTERY BSL 1850MA (EUROPE,AUS,NZL)	2	INCLUD.502
*59	378681M	BATTERY BSL 1840M (USA,CAN)	1	INCLUD.502
*60	341211	WIRING ASS'Y	1	INCLUD.61
*60	341210	WIRING ASS'Y	1	INCLUD.61 FOR USA,CAN
61	382676	PANEL SHEET (A)	1	
62	371020	O-RING (I.D 2.5)	2	
63	332000	SPRING (T)	1	
64	371021	TRIGGER	1	
65	371019	SWITCH CABLE (A)	1	
66	331790	LEVER (C)	1	
67	382821	O-RING (I.D 3.8)	1	
68	326276	LEVER (A)	1	
*69	382722	HOUSING SET	1	
*69	382722M	HOUSING SET	1	FOR USA,CAN
70	382724	GEAR BOX ASS'Y	1	INCLUD.72
71	361245	ROTOR	1	
72	372342	BUMPER (B)	2	
73	377288	HEX. SOCKET SET SCREW M5X10	1	
74	382386	RUBBER CUSHION (A)	1	
75	372304	ROLL PIN D2.5X8	2	
76	885318	ROLL PIN D2.5X25	1	
77	878965	ROLL PIN D2.5X16	1	
78	6696839	WIRE BAND	1	
79	382822	MAGNET (A)	4	
80	382698	SLIDER	1	
81	382699	MAGNET HOLDER	4	
82	382700	SENSOR (C)	1	
83	382720	DETECTOR SPRING	1	
84	382719	BLADE DETECTOR	1	
85	382701	SPACER	1	
86	880413	NYLOCK HEX. SOCKET HD. BOLT M4X10	1	
87	872822	O-RING (S-5)	1	
*88	382751	MAGAZINE ASS'Y	1	INCLUD.89-92,94-97,100-102,104-108
*88	382750	MAGAZINE ASS'Y	1	INCLUD.89-97,100-108 FOR USA,CAN
89	890477	NYLON NUT M6	1	
90	382745	MAGAZINE COVER	1	
91	380792	BOLT WASHER D6	1	
92	382730	TORX FLANGE BUTTON BOLT M6X12	1	
*93	382717	CAUTION LABEL	1	FOR USA,CAN
94	381736	NYLOCK BOLT (W/FLANGE) M6X10	1	
95	381735	DISTANCE PIECE (C)	1	
96	381734	MAGAZINE RUBBER	1	
97	949861	ROLL PIN D2X12 (10 PCS.)	1	
98	382746	BLADE GUIDE (A)	1	
99	949685	ROLL PIN D3X20 (10 PCS.)	1	
100	382739	BLADE GUIDE (B)	1	
101	372350	SPRING	1	
102	382684	MAGNET ARM	1	

\* ALTERNATIVE PARTS

# HIKOKI

## CORDLESS NAILER NR1890DRA

Item No.	Code No.	Description	No. Used	Remarks
*103	382749	LABEL (D)	1	FOR USA,CAN
104	382740	MAGAZINE	1	
105	382743	NAIL RAIL	1	
106	382742	NAIL FEEDER	1	
107	883503	RIBBON SPRING	1	
108	381738	NEEDLE ROLLER	1	
109	382730	TORX FLANGE BUTTON BOLT M6X12	1	
110	382734	REPAIR PARTS SET (NR)	1	INCLUD. 1, 4-6, 9, 11, 12, 14, 16-20, 64, 74
		STANDARD ACCESSORIES		
*501		CHARGER (MODEL UC 18YSL3)	1	
*501		CHARGER (MODEL UC 18YFSL)	1	
502	329897	BATTERY COVER	1	
503	382494	TORX BAR WRENCH	1	
504	875769	PROTECTIVE GLASSES	1	
*505	382493	NOSE CAP	1	FOR EUROPE
*506	66A2942	TOOL BAG 410X330	1	FOR EUROPE
*507	372294M	TOOL BAG	1	FOR USA,CAN
*508	382718	INNER TRAY	1	FOR EUROPE
*509	337528	CASE ASS'Y (STACKABLE 4)	1	INCLUD. 510-512 FOR EUROPE
*510	336472	LATCH	4	FOR EUROPE
*511	336473	HANDLE	1	FOR EUROPE
*512	336474	HINGE	2	FOR EUROPE
		OPTIONAL ACCESSORIES		
601	382756	GREASE (SYNTHESO GLEP1) 40G	1	
602	325149	GREASE (MOLUB-ALLOY NO.777-1) 75G	1	
603	317918	GREASE (ATTOLUB NO.2) 500G	1	
604	382741	MAGAZINE	1	
605	382744	NAIL RAIL	1	
*606	382418	MAGAZINE ASS'Y (ACCESSORY)	1	INCLUD. 89-92, 94-97, 100-102, 106-108, 604, 605
*606	382418M	MAGAZINE ASS'Y (ACCESSORY)	1	INCLUD. 89-97, 100-103, 106-108, 604, 605
				FOR USA,CAN

\* ALTERNATIVE PARTS