

ENGINE TOOL PARTS LIST

ENGINE HEDGE TRIMMER Model CH 22EBP2

2013-3-11

(E1)

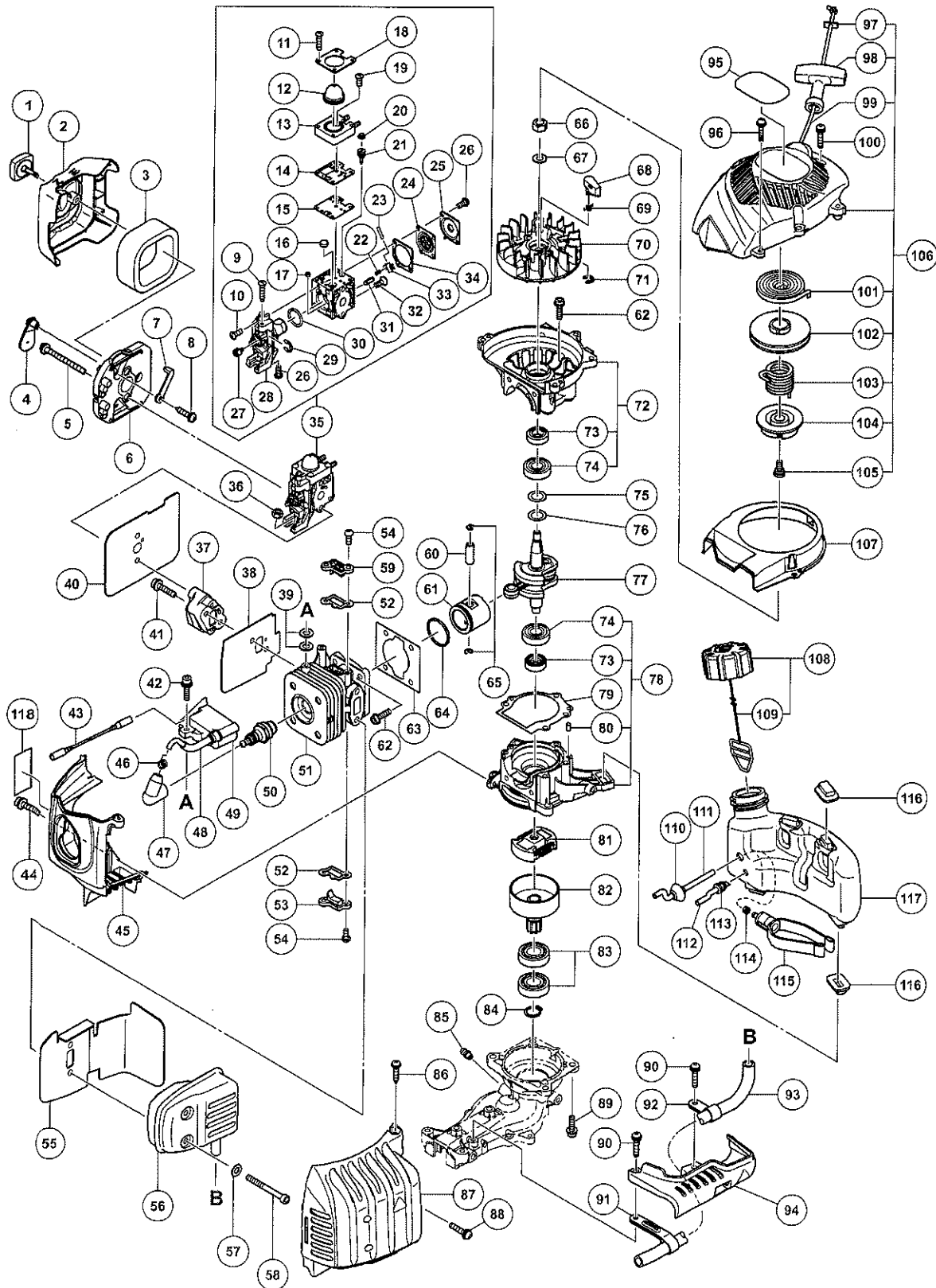

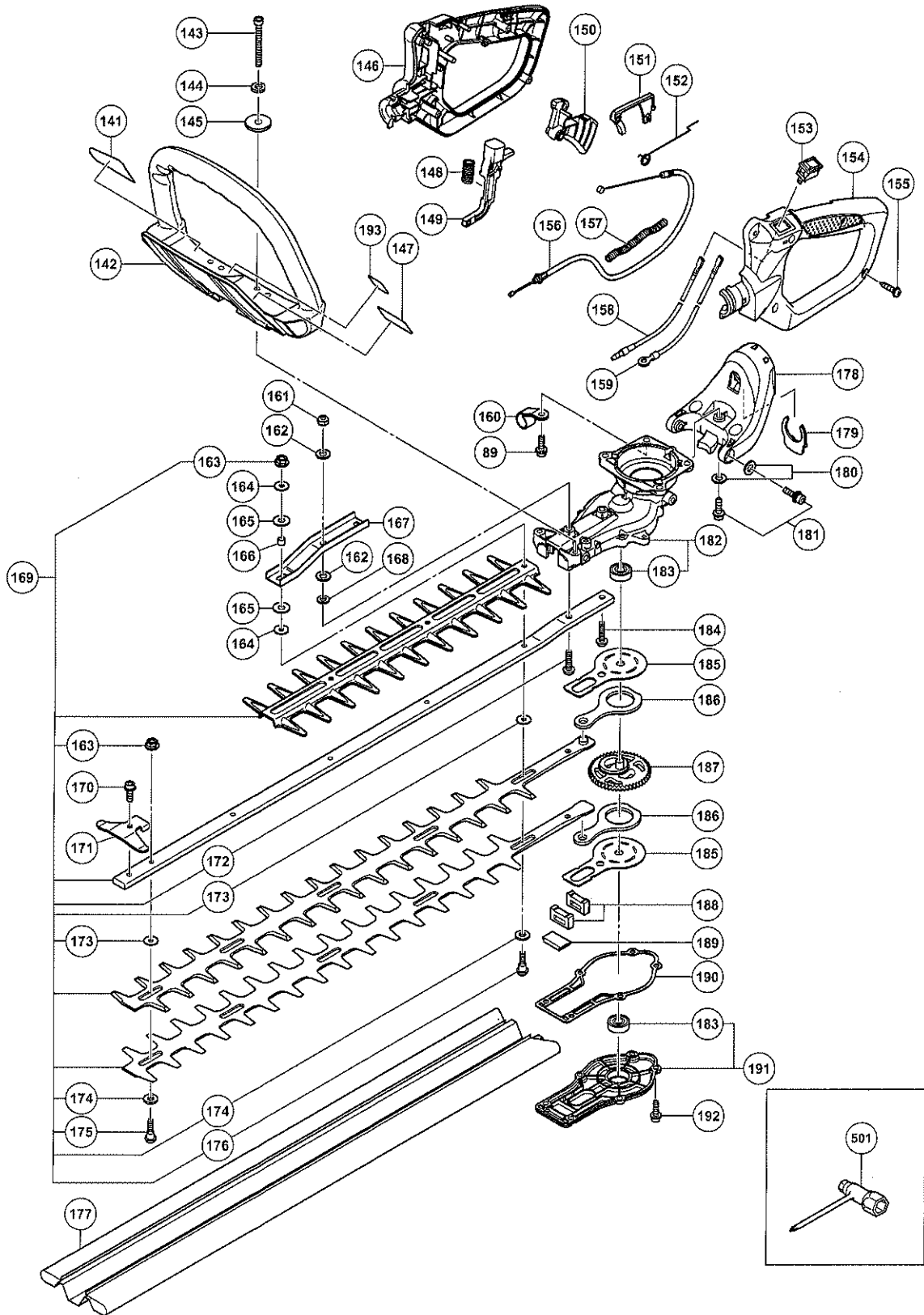

PARTS

CH 22EBP2

ITEM NO.	CODE NO.	DESCRIPTION	NO. USED	REMARKS
1	669-8730	COVER FIXING BOLT COMP.	1	
2	669-8809	CLEANER COVER	1	
3	669-0365	CLEANER SPONGE	1	
4	669-8608	CHOKE VALVE	1	
5	307-224	MACHINE SCREW (W/WASHERS) M5 X 60 (BLACK)	2	
6	669-8606	CLEANER BODY	1	
7	669-8607	CHOKE HANDLE	1	
8	309-470	TAPPING SCREW (W/FLANGE) D4 X 12 (BLACK)	1	
9	669-9087	THROTTLE ADJUST SCREW (TAS)	1	
10	669-9088	SET SCREW (B)	3	
11	669-9100	SET SCREW (D)	4	
12	669-9098	SYRINGE	1	
13	669-9097	PRIMER BASE	1	
14	669-9096	PUMP GASKET	1	
15	669-9095	PUMP DIAPHRAGM	1	
16	669-9080	STRAINER	1	
17	669-9103	GUIDE PIN ROLLER	1	
18	669-9099	SYRINGE RETAINER	1	
19	669-9101	SET SCREW (E)	1	
20	669-9104	BALL PLUG RETAINER	1	
21	669-9105	ADJUSTING SCREW (MAIN MIXTURE)	1	
22	669-9083	METERING LEVER SPRING	1	
23	669-9082	PIN	1	
24	669-9091	METERING DIAPHRAGM	1	
25	669-9093	METERING COVER	1	
26	669-9094	SET SCREW (C)	3	
27	669-9089	POST	1	
28	669-9086	ROTOR COVER	1	
29	669-9090	RETAINING RING (E-TYPE) FOR D2.5 SHAFT	1	
30	669-9102	O-RING	1	
31	669-9081	INLET NEEDLE VALVE	1	
32	669-9085	SET SCREW (A)	1	
33	669-9084	METERING LEVER	1	
34	669-9092	METERING GASKET	1	
35	669-9078	CARBURETOR ASS'Y	1	INCLUD. 9-34
36	949-567	LOCK NUT M6 (10 PCS.)	1	
37	669-8387	CARBURETOR INSULATOR	1	
38	669-8605	INTAKE PACKING	1	
39	669-8700	GLASS WASHER	4	
40	669-8816	CARBURETOR PACKING	1	
41	669-8844	SEAL LOCK HEX. SOCKET BOLT (W/WASHERS) M5	2	
42	669-8388	HEX. SOCKET HD. BOLT (W/WASHERS) M4 X 18	2	
43	669-9060	CORD	1	
44	669-8879	SEAL LOCK HEX. SOCKET HD. BOLT M4 X 12	1	
45	669-8871	CYLINDER COVER	1	
46	669-9180	METAL OF PLUG CAP (60) (B)	1	
47	669-8548	PLUG CAP	1	
48	669-9175	CORD INSULATION TUBE	1	
49	669-8602	IGNITION COIL	1	
50	668-4584	SPARK PLUG BMR7A	1	

PARTS

CH 22EBP2

ITEM NO.	CODE NO.	DESCRIPTION	NO. USED	REMARKS
* 50	668-5052	SPARK PLUG CJ6	1	FOR USA
51	669-8597	CYLINDER	1	
52	669-6534	COVER PACKING	2	
53	669-6535	INTAKE COVER (A)	1	
54	669-6835	SEAL LOCK SCREW M4 X 10	4	
55	669-8617	HEAT PROTECTION PANEL	1	
56	669-8733	MUFFLER	1	
57	949-432	BOLT WASHER M6 (10 PCS.)	2	
58	669-8819	HEX. SOCKET HD. BOLT M6 X 55	2	
59	669-6536	INTAKE COVER (B)	1	
60	669-6944	PISTON PIN	1	
61	669-6531	PISTON	1	
62	669-8386	HEX. SOCKET HD. BOLT (W/SP. WASHER) M5 X 18	8	
63	669-6530	CYLINDER PACKING	1	
64	669-6532	PISTON RING	1	
65	668-4590	CIR CLIP	2	
66	669-6879	FLYWHEEL NUT M7	1	
67	669-6880	BOLT WASHER D7	1	
68	669-8603	STARTER PAWL	2	
69	668-5335	STARTER PAWL SPRING	2	
70	669-8601	MAGNETO ROTOR	1	
71	668-5336	RETAINING RING D4	2	
72	669-8872	CRANK CASE (B) ASS'Y	1	INCLUD. 73, 74
73	668-4607	OIL SEAL TB 12227	2	
74	668-4608	BALL BEARING 6001 C3	2	
75	669-6946	SHIM T0.2	1	
76	669-6945	SHIM T0.3	1	
77	669-9043	CRANK SHAFT	1	
78	669-8729	CRANK CASE (A) ASS'Y	1	INCLUD. 73, 74, 80
79	669-6539	CRANK CASE PACKING	1	
80	669-6947	KNOCK PIN 4 X 12	2	
81	669-9173	CLUTCH (B)	1	
82	669-9040	CLUTCH DRUM	1	
83	669-8740	BALL BEARING 6002ZC3	2	
84	939-544	RETAINING RING FOR D15 SHAFT (10 PCS.)	1	
85	668-8643	GREASE NIPPLE COMP.	1	
86	302-089	TAPPING SCREW (W/FLANGE) D5 X 20 (BLACK)	1	
87	669-8876	MUFFLER PROTECTOR	1	
88	887-021	SCREW (W/WASHERS) M5 X 16 (BLACK)	1	
89	669-5495	HEX. HOLE BOLT 6 X 18/S	4	
90	669-8988	HEX. SOCKET HD. BOLT (W/BUTTON) M5 X 20	2	
91	669-9047	FIXATION PLATE (A)	1	
92	669-9048	FIXATION PLATE (B)	1	
93	669-9052	TAIL PIPE (A)	1	
94	669-9037	EXHAUST COVER	1	
95		HITACHI LABEL	1	
96	669-8878	TAPPING SCREW D4.5 X 16	1	
97	668-5189	PLATE	1	
98		STARTER KNOB	1	
99		STARTER ROPE	1	

PARTS

CH 22EBP2

ITEM NO.	CODE NO.	DESCRIPTION	NO. USED	REMARKS
100	669-8988	HEX. SOCKET HD. BOLT (W/BUTTON) M5 X 20	3	
101	669-7591	RECOIL SPRING	1	
102	669-3072	STARTER ROPE REEL	1	
103	668-5183	DAMPER SPRING	1	
104		CAM PLATE	1	
105	668-4679	SET SCREW	1	
* 106	669-8622	RECOIL STARTER ASS'Y	1	INCLUD. 97-99, 101-105
* 106	669-8623	RECOIL STARTER ASS'Y	1	INCLUD. 97-99, 101-105 FOR USA
107	669-8624	AIR DEFLECTOR	1	
108	669-8402	FUEL TANK CAP ASS'Y	1	INCLUD. 109
109	669-8732	TANK CAP CHAIN	1	
110	669-8931	FUEL GROMMET	1	
111	669-8873	FUEL PIPE	1	
112	669-8875	FUEL PIPE (PINK)	1	
113	669-6970	RETURN GROMMET	1	
114	669-6949	CLIP	1	
115	669-8874	PUMP FILTER	1	
116	669-8615	CUSHION RUBBER	4	
* 117	669-8613	TANK	1	
* 117	669-8612	TANK (A)	1	FOR USA
118		CAUTION LABEL	1	
141		NAME PLATE	1	
142	669-9079	HANDLE	1	
143	669-8885	SEAL LOCK HEX. SOCKET HD. BOLT M5 X 40	2	
144	669-8884	SPRING WASHER M5	2	
145	669-8749	BRAKE AXIS WASHER	2	
146	669-8880	HANDLE A	1	
147		CAUTION LABEL	1	
148	669-6348	SPRING (A)	1	
* 149	669-9055	LOCK LEVER	1	
* 149	669-9056	LOCK LEVER	1	FOR USA
* 150	669-9053	THROTTLE LEVER	1	
* 150	669-9054	THROTTLE LEVER	1	FOR USA
* 151	669-6344	TRIGGER LOCKOUT	1	
* 151	669-8626	TRIGGER LOCKOUT	1	FOR USA
152	669-6345	THROTTLE LEVER SPRING	1	
153	669-6940	STOP SWITCH	1	
154	669-9051	HANDLE B	1	
155	305-812	TAPPING SCREW (W/FLANGE) D4 X 16 (BLACK)	4	
156	669-8627	THROTTLE WIRE	1	
157	669-8738	PROTECTION TUBE	1	
158	669-9058	STOP SWITCH CORD	1	
159	669-9059	STOP SWITCH CORD (B)	1	
160	669-9049	FIXATION PLATE (B)	1	
161	669-8766	NYLON NUT M6	2	
162	668-4639	BOLT WASHER 6	4	
163	669-9108	U-NUT M5	5	
164	669-9114	WASHER (A)	2	
165	669-9178	RUBBER WASHER	2	
166	669-2244	COLLAR 5.8	1	

PARTS

CH 22EBP2

ITEM NO.	CODE NO.	DESCRIPTION	NO. USED	REMARKS
167	669-9177	SUPPORT PLATE	1	
168	949-432	BOLT WASHER M6 (10 PCS.)	2	
169	669-9061	BLADE ASS'Y (620 MM)	1	INCLUD. 163, 172-176
170	669-9065	HEX. SOCKET HD. BOLT (W/FLANGE) M5 X 8	1	
171	669-9062	GUARD PLATE	1	
172	669-9113	HEX. SOCKET HD. BOLT (W/BUTTON) M6 X 25	1	
173	669-9114	WASHER (A)	5	
174	669-9111	WASHER M7	5	
175	669-9109	SHOULDER BUTTON BOLT M5 X 25	4	
176	669-9179	SHOULDER BUTTON BOLT M5 X 31	1	
177	669-8948	BLADE CASE (FOR 620 MM)	1	
178	669-9041	HANDLE BRACKET	1	
179	669-6359	CLIP	1	
180	668-5407	BOLT WASHER D5	3	
181	669-9044	SEAL LOCK HEX. SOCKET BOLT (W/WASHERS) M5	3	
182	669-9070	GEAR CASE (A) ASS'Y	1	INCLUD. 183
183	669-8772	BALL BEARING 608ZZC3	2	
184	669-9113	HEX. SOCKET HD. BOLT (W/BUTTON) M6 X 25	1	
185	669-9063	GUIDE PLATE (B)	2	
186	669-8987	CAM ROD	2	
187	669-9066	GEAR 2	1	
188	669-9068	FELT PACKING (B)	2	
189	669-9067	FELT PACKING (C)	1	
190	669-9042	GEAR CASE PACKING	1	
191	669-9071	GEAR CASE (B) ASS'Y	1	INCLUD. 183
192	669-9069	HEX. SOCKET HD. BOLT (W/SP. WASHER) M5 X 14	6	
* 193		START LABEL (B)	1	FOR USA

STANDARD ACCESSORIES

ITEM NO.	CODE NO.	DESCRIPTION	NO. USED	REMARKS
501	669-8756	BOX WRENCH 10/19 MM	1	