

## ELECTRIC TOOL PARTS LIST

**CORDLESS DRIVER DRILL**  
**Model DS 14DL**

**2006 · 7 · 5**  
**(E1)**

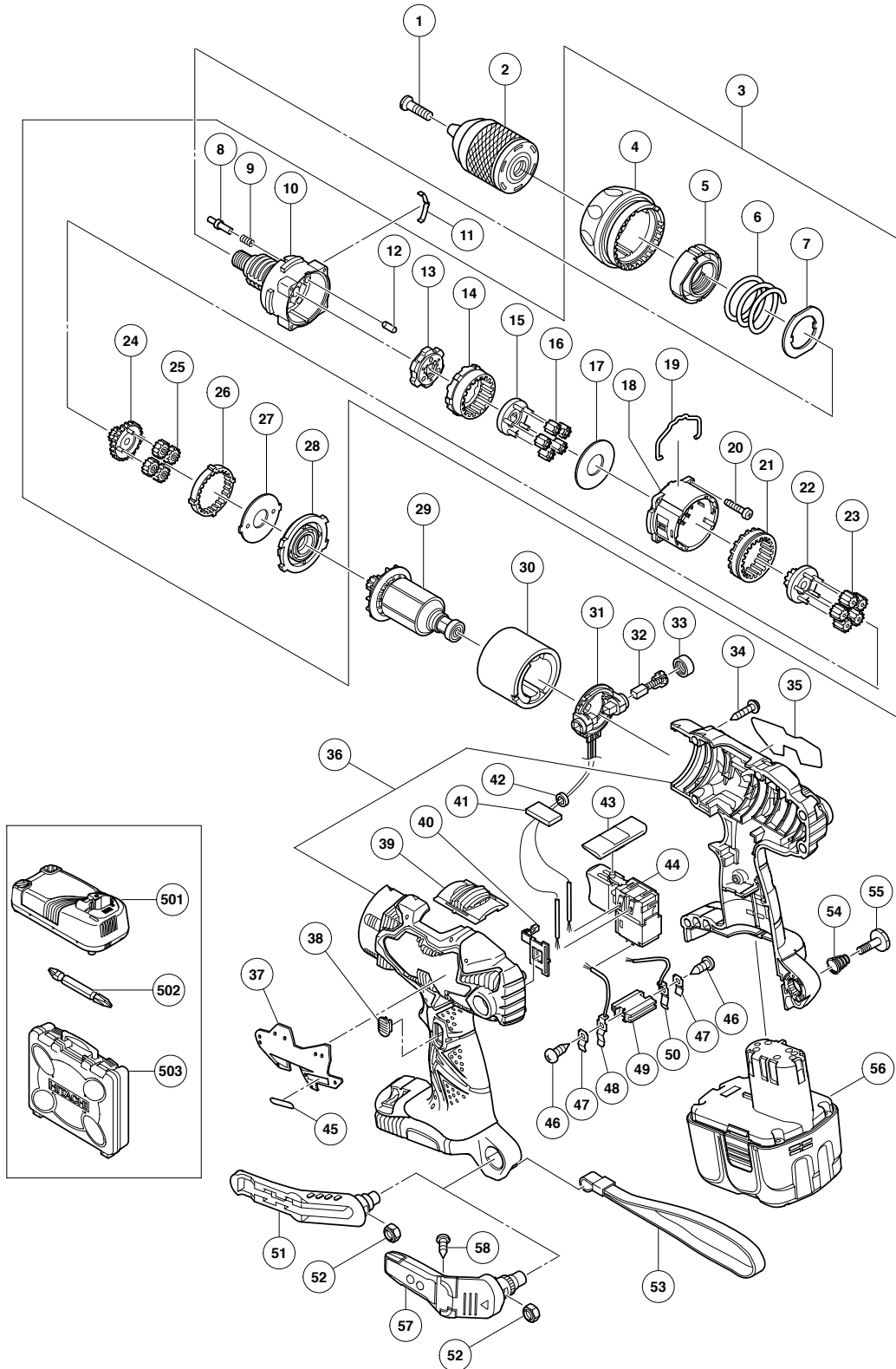

**PARTS**

DS 14DL

ITEM NO.	CODE NO.	DESCRIPTION	NO. USED	REMARKS
1	311-959	SPECIAL SCREW (LEFT HAND) M6X23	1	
2	323-898	DRILL CHUCK 13VLRN (W/O CHUCK WRENCH)	1	
3	322-969	GEAR BOX ASS'Y	1	INCLUD. 4-10, 12-28
4	322-991	FRONT CAP	1	
5	322-974	NUT	1	
6	323-228	SPRING	1	
7	322-973	THRUST WASHER	1	
8	322-972	STOPPER	2	
9	322-971	STOPPER SPRING	2	
10	322-970	FRONT CASE	1	
11	323-231	CLICK SPRING	1	
12	322-975	PIN SET (6 PCS.)	6	
13	322-976	LOCK RING	1	
14	322-977	RING GEAR	1	
15	322-978	CARRIER	1	
16	322-979	PLANET GEAR (C) SET (5 PCS.)	5	
17	322-980	WASHER (A)	1	
18	322-981	REAR CASE	1	
19	322-990	SHIFT ARM	1	
20	315-817	SCREW SET D3X12 (6 PCS.)	4	
21	322-983	SLIDE RING GEAR	1	
22	322-982	PINION (C)	1	
23	322-984	PLANET GEAR (B) SET (5 PCS.)	5	
24	322-985	PINION (B)	1	
25	322-987	PLANET GEAR (A) SET (4 PCS.)	4	
26	322-986	FIRST RING GEAR	1	
27	322-988	WASHER (B)	1	
28	322-989	MOTOR SPACER	1	
29	360-658	ARMATURE AND PINION SET	1	
30	322-996	MAGNET	1	
31	322-993	BRUSH BLOCK	1	
32	999-054	CARBON BRUSH 5X6X11.5 (1 PAIR)	2	
33	319-918	BRUSH CAP	2	
34	313-687	TAPPING SCREW (W/FLANGE) D3X16 (BLACK)	10	
35		NAME PLATE	1	
36	326-280	HOUSING (A).(B) SET	1	
37	326-279	PLATE (A)	1	
38	326-276	LEVER (A)	1	
39	324-137	SHIFT KNOB	1	
40	326-277	LEVER (B)	1	
* 41	326-493	SUPPORT (D)	1	EXCEPT FOR AUS
* 42	323-229	FERRITE CORE	1	EXCEPT FOR AUS
43	322-997	PUSHING BUTTON	1	
44	322-994	DC-SPEED CONTROL SWITCH	1	
45		HITACHI LABEL	1	
46	958-715	TAPPING SCREW D4X10	2	
47	996-118	HOLDER SPRING	2	
48	323-003	TERMINAL	1	
49	320-997	TERMINAL PIECE	1	
50	322-995	TERMINAL	1	
* 51	320-287	HOOK ASS'Y	1	INCLUD. 52 FOR AUS, FRG, NOR, SWE, DEN



