

## ELECTRIC TOOL PARTS LIST

### ■ CORDLESS DRIVER DRILL

2010-9-27

### Model DS 14DSFL

(E1)

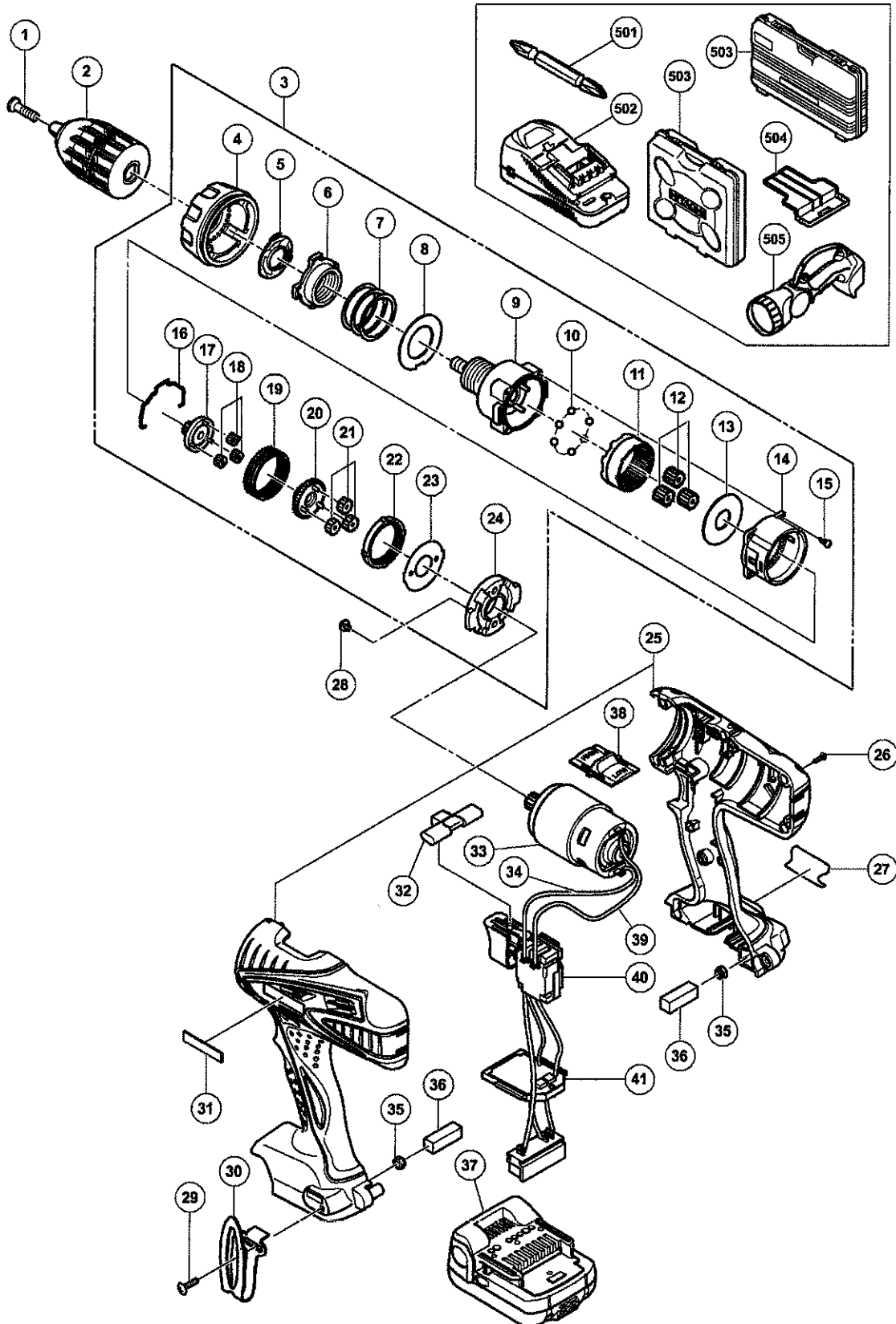

**PARTS**

DS 14DSFL

ITEM NO.	CODE NO.	DESCRIPTION	NO. USED	REMARKS
1	311-959	SPECIAL SCREW (LEFT HAND) M6 X 23	1	
* 2	332-050	DRILL CHUCK 10VLRH-N	1	
* 2	332-043	DRILL CHUCK 10VLRH-N	1	FOR USA, CAN
3	333-315	GEAR BOX ASS'Y	1	INCLUD. 4-24
4	332-025	CLUTCH DIAL	1	
5	332-741	CLICK SPRING	1	
6	324-109	NUT	1	
7	324-110	SPRING	1	
8	324-347	WASHER (D)	1	
9	333-314	FRONT CASE	1	
10	306-936	STEEL BALL D5	6	
11	332-027	RING GEAR	1	
12	332-028	PLANET GEAR (C) SET (3 PCS.)	3	
13	324-349	WASHER (A)	1	
14	324-501	REAR CASE	1	
15	324-357	SCREW SET D3 X 12 (4 PCS.)	4	
16	324-115	SHIFT ARM	1	
17	332-029	PINION (C)	1	
18	332-031	PLANET GEAR (B) SET (3 PCS.)	3	
19	332-030	SLIDE RING GEAR (B)	1	
20	332-032	PINION (B)	1	
21	332-034	PLANET GEAR (A) SET (3 PCS.)	3	
22	332-033	FIRST RING GEAR	1	
23	324-355	WASHER (B)	1	
24	332-035	MOTOR SPACER	1	
* 25	333-312	HOUSING (A). (B) SET	1	
* 25	332-820	HOUSING (A). (B) SET	1	FOR USA, CAN
26	313-687	TAPPING SCREW (W/FLANGE) D3 X 16 (BLACK)	9	
27		NAME PLATE	1	
28	317-333	MACHINE SCREW (W/SP. WASHER) M4 X 6	2	
29	327-001	TRUSS HD. SCREW M4 (BLACK)	1	
30	332-824	HOOK	1	
31	330-719	HITACHI LABEL	1	
32	332-836	PUSHING BUTTON	1	
33	332-559	MOTOR DC 14.4V	1	
34	332-843	INTERNAL WIRE (BLACK) 130L	1	
35	327-002	LOCK NUT M4 (BLACK)	2	
36	327-004	PACKING	2	
* 37	329-877	BATTERY BSL 1415 (EUROPE)	2	INCLUD. 504
* 37	333-351	BATTERY BSL 1415 (USA, CAN)	2	INCLUD. 504
38	332-036	SHIFT KNOB	1	
39	324-499	INTERNAL WIRE (RED) 140L	1	
40	332-822	DC-SPEED CONTROL SWITCH	1	
41	332-823	CONTROLLER TERMINAL SET	1	

