

H38

()

EA2(ST)

Serial No.

H38-01 CYLINDER/PISTON/CRANK SHAFT

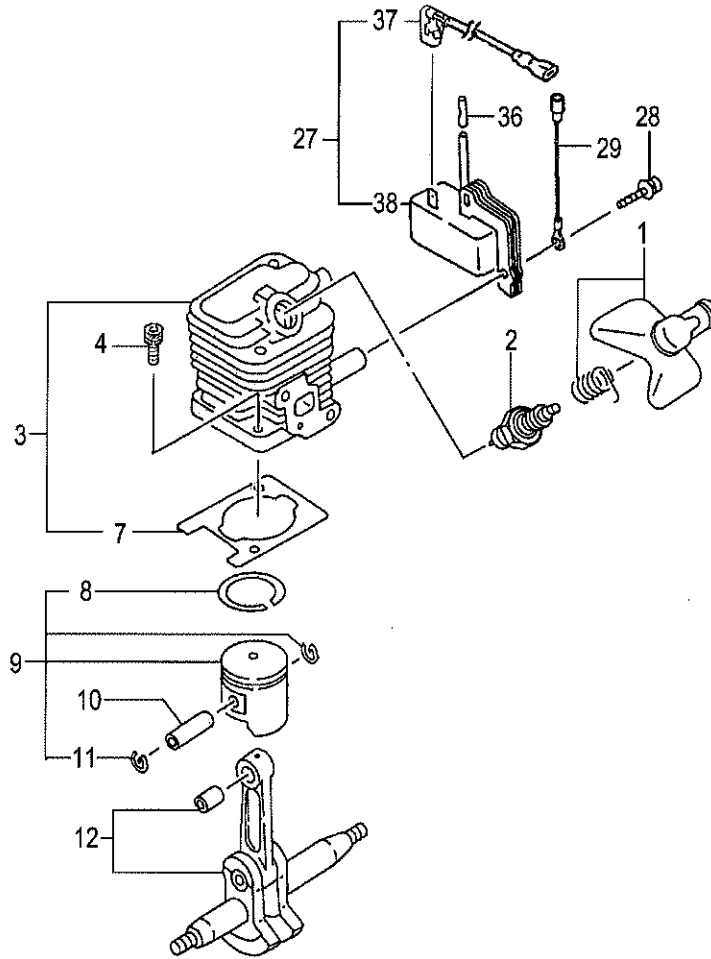

REF. NUMBER	PARTS NUMBER	DESCRIPTION	Q'TY	REMARKS /SERIAL NO.
H38-01 CYLINDER/PISTON/CRANK SHAFT				
001	668-7476	SPARK PLUG CAP ASS'Y	1	
002	668-5086	SPARK PLUG BPMR6A	1	
003	668-5480	CYLINDER SET	1	
004	668-4586	HEX.HOLE BOLT M5X18/S	2	
007	668-5744	CYLINDER GASKET	1	
008	668-6118	PISTON RING	1	
009	668-5869	PISTON SET	1	
010	668-6015	PISTON PIN	1	
011	668-4590	PISTON PIN CIRCLIP	2	
012	668-6208	CRANK SHAFT COMP	1	
027	668-7353	IGNITIONCOIL ASS'Y	1	
028	668-4599	HEX.HOLE BOLT M4X18/WS	2	
029	668-8477	CORD	1	
036	668-4597	INSULATOR TUBE 50L	1	
037	668-7918	CORD 200M	1	
038	668-7698	IGNITION COIL COMP.	1	- E190090
038	668-7702	IGNITION COIL COMP.	1	E290001 -

H38-02 CRANK CASE

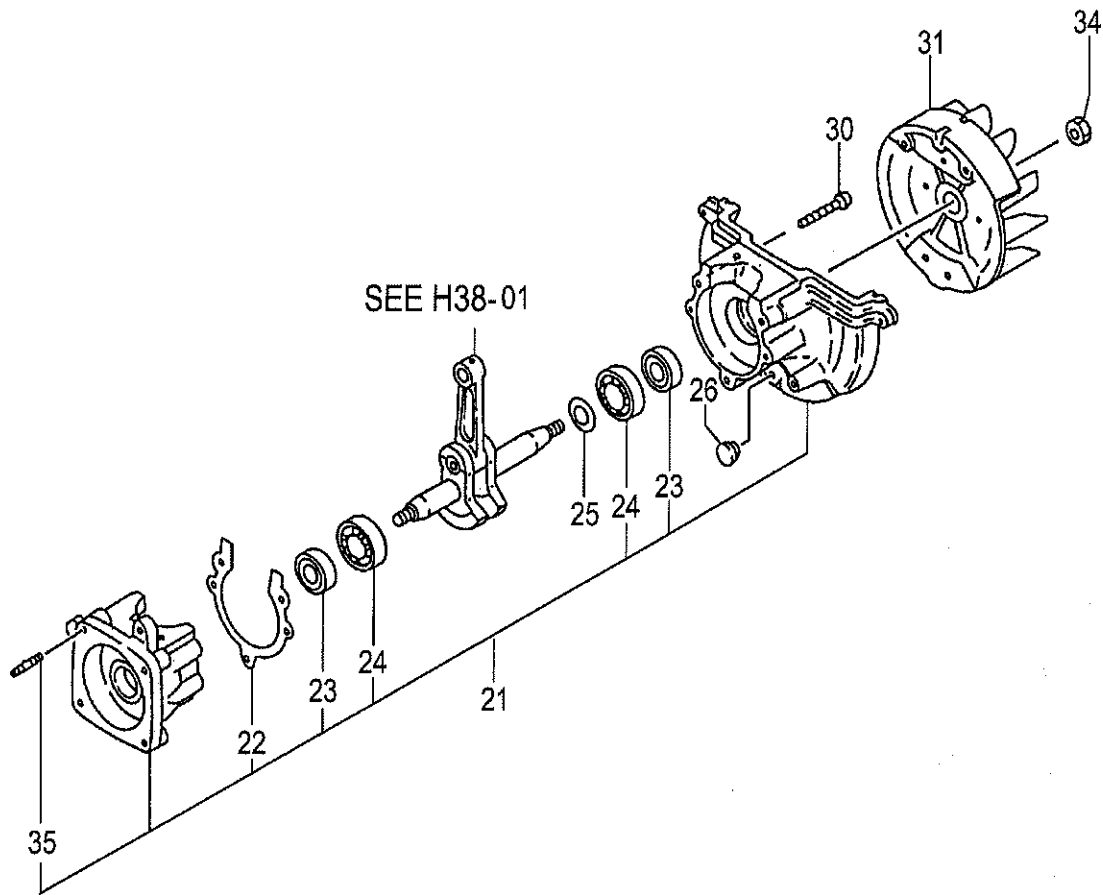

REF. NUMBER	PARTS NUMBER	DESCRIPTION	Q'TY	REMARKS /SERIAL NO.
H38-02 CRANK CASE				
021	668-6574	CRANK CASE ASS'Y	1	
022	668-6720	CRANKCASE GASKET	1	
023	668-4607	OIL SEAL TB 12227	2	
024	668-4608	BALL BEARING 6001 C3	2	
025	668-4604	GEAR SHAFT SHIM 0.20	V	
025	668-4605	GEAR SHAFT SHIM 0.30	V	
026	669-1822	ANTI-VIBE RUBBER	1	
030	668-4786	HEX. SOCKET HD. BOLT M5X30 S	3	
031	668-7396	MAGNETO ROTOR COMP.	1	
034	668-4612	HEX.NUT M8	1	
035	668-6771	STUD BOLT 6X22	2	

H38-03 ENGINE-1

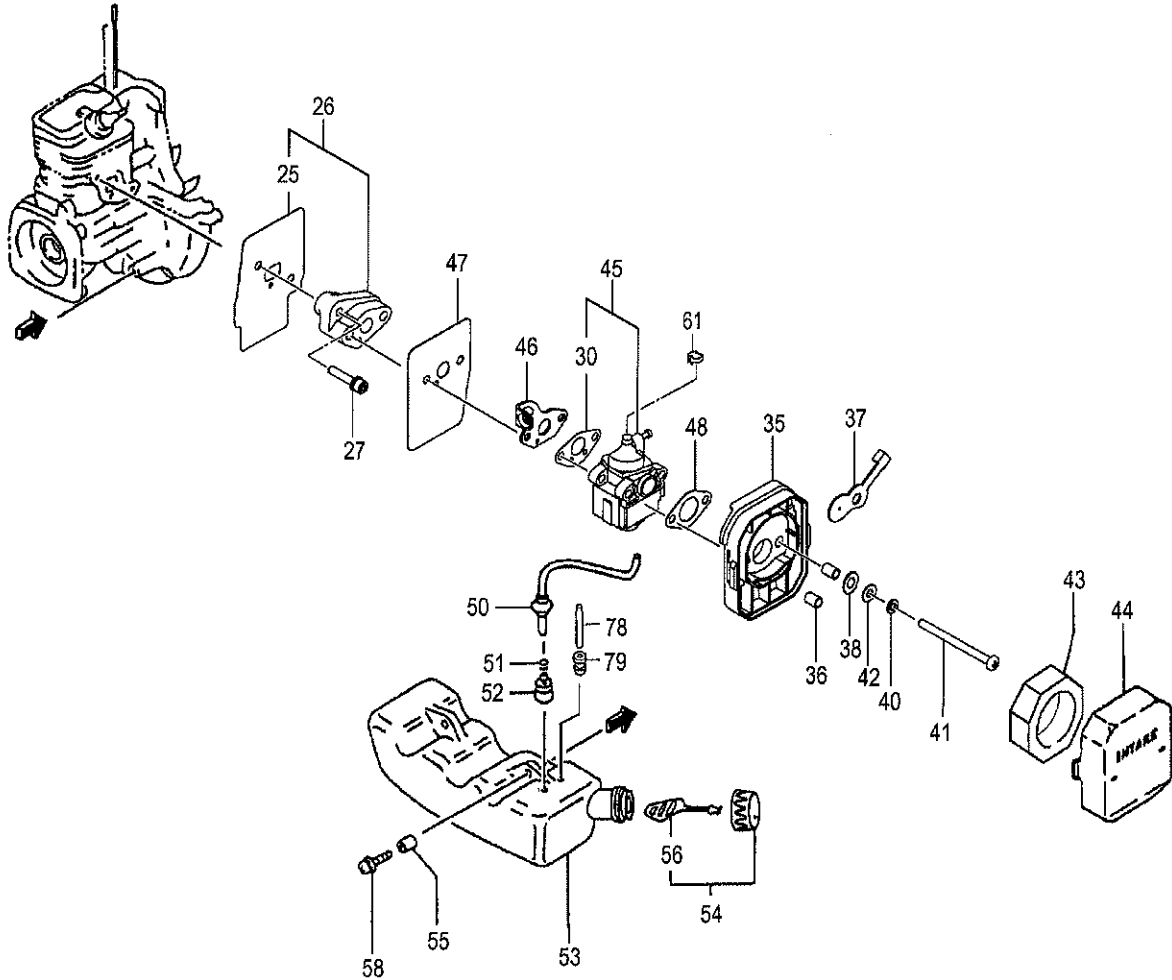

REF. NUMBER	PARTS NUMBER	DESCRIPTION	Q'TY	REMARKS /SERIAL NO.
H38-03 ENGINE-1				
025	668-9891	INTAKE PIPE GASKET	1	
026	668-9966	CARB. INSULATOR SET, SPARE	1	
027	669-5515	HEX. HOLE BOLT 5X25WS	2	
030	668-4615	CARBURETOR GASKET	1	
035	669-0091	CLEANER BODY COMP.	1	
036	669-0801	COLLAR	2	
037	669-1267	CHOKE PLATE, W/1.5MM HOLE	1	
038	668-4859	SPACER	1	
040	668-4662	S. WASHER 5	2	
041	669-4918	SCREW 5X65	2	
042	668-4661	WASHER 5	2	
043	669-0350	CLEANER ELEMENT	1	
044	669-0142	AIR CLEANER CAP	1	
045	669-0495	CARBURETOR SET WYL212	1	
046	668-4629	THROTTLE WIRE FIXING PLATE	1	
047	668-9839	CARBURETOR GASKET	1	
048	669-0184	CLEANER GASKET	1	
050	668-5247	SHIELD TUBE ASS'Y	1	
051	668-4619	CLIP, 6.3 DIA.	1	
052	668-4620	PUMP FILTER BODY COMP.	1	
053	669-1647	TANK WHT	1	
054	669-1763	TANK CAP D ASS'Y, BLACK	1	
055	669-2244	COLLAR 5.8	2	
056	668-4625	TANK CAP CHAIN	1	
058	669-5505	HEX. HOLE BOLT 5X18PS	2	
061	668-4628	SWIVEL CAP	1	
078	669-2357	FUEL PIPE 3X5X70	1	
079	668-4627	RETURN GROMMET	1	

H38-04 ENGINE-2

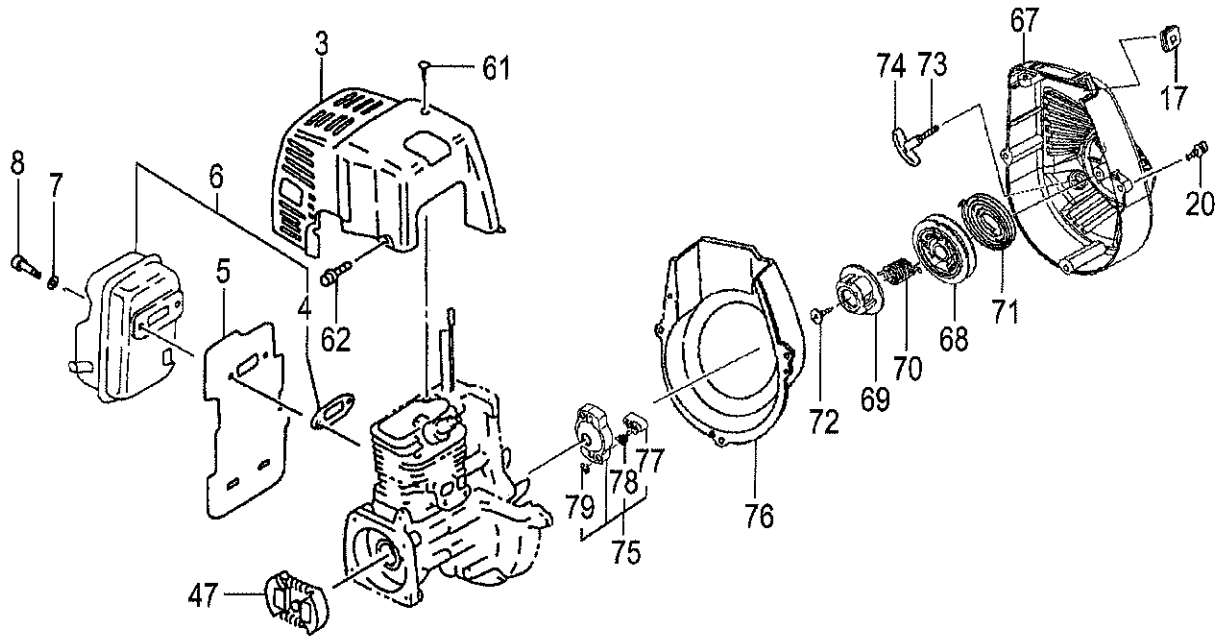

REF. NUMBER	PARTS NUMBER	DESCRIPTION	Q'TY	REMARKS /SERIAL NO.
H38-04 ENGINE-2				
003	669-2795	MUFFLER PROTECTOR	1	
004	669-2744	MUFFLER GASKET	1	
005	668-7252	HEAT SHIELD	1	
006	669-2481	MUFFLER SET	1	
007	668-4661	WASHER 5	2	
008	668-5114	HEX. SOCKET HD. BOLT M5X50	2	
017	668-8050	GROMMET	1	
020	669-5502	HEX.HOLE BOLT 4X18PS	3	
047	668-8494	CLUTCH ASS'Y	1	
061	668-4636	TAPPING SCREW D4.5X16	1	
062	669-5441	BOLT 4X12PS	2	
067	668-7014	FAN CASE COMP.	1	
068	669-3072	STARTER ROPE REEL	1	
069	668-4678	CAM PLATE	1	
070	668-4677	DUMPER SPRING	1	
071	668-4675	RECOIL SPRING	1	
072	668-4679	SET SCREW	1	
073	669-3172	ROPE 3X890	1	
074	669-3237	STARTER HANDLE	1	
075	668-4681	STARTER PULLEY ASS'Y	1	
076	668-7209	DEFLECTOR	1	
077	668-4685	STARTER PAWL	2	
078	668-4684	STARTER PAWL SPRING	2	
079	668-4683	STOP RING E-5	2	

H38-05 CARBURETOR

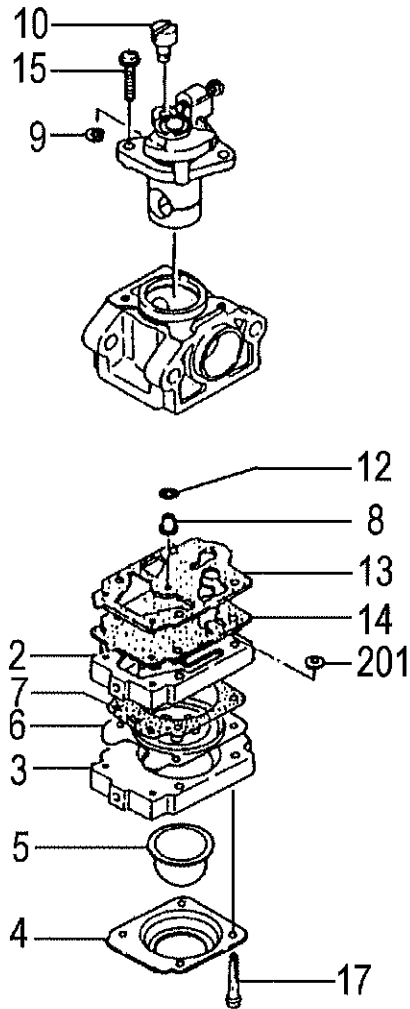

REF. NUMBER	PARTS NUMBER	DESCRIPTION	Q'TY	REMARKS /SERIAL NO.
H38-05 CARBURETOR				
002	669-1433	PUMP BODY COMP.	1	
003	668-4687	PRIMING PUMP COMP.	1	
004	668-4688	DIAPHRAGM COVER	1	
005	668-4689	PRIMING BODY	1	
006	669-0830	METERING DIAPHRAGM COMP.	1	
007	668-4691	DIAPHRAGM GASKET	1	
008	668-4878	MAIN JET #39	1	
009	668-4696	STOP RING	1	
010	668-4697	SWIVEL	1	
012	668-4695	O-RING	1	
013	669-1457	PUMP GASKET	1	
014	668-4693	PUMP DIAPHRAGM	1	
015	668-4698	THROTTLE SET SCREW	2	
017	668-4699	SET SCREW	4	
201	668-4700	INLET SCREEN	1	

H38-06 HANDLE

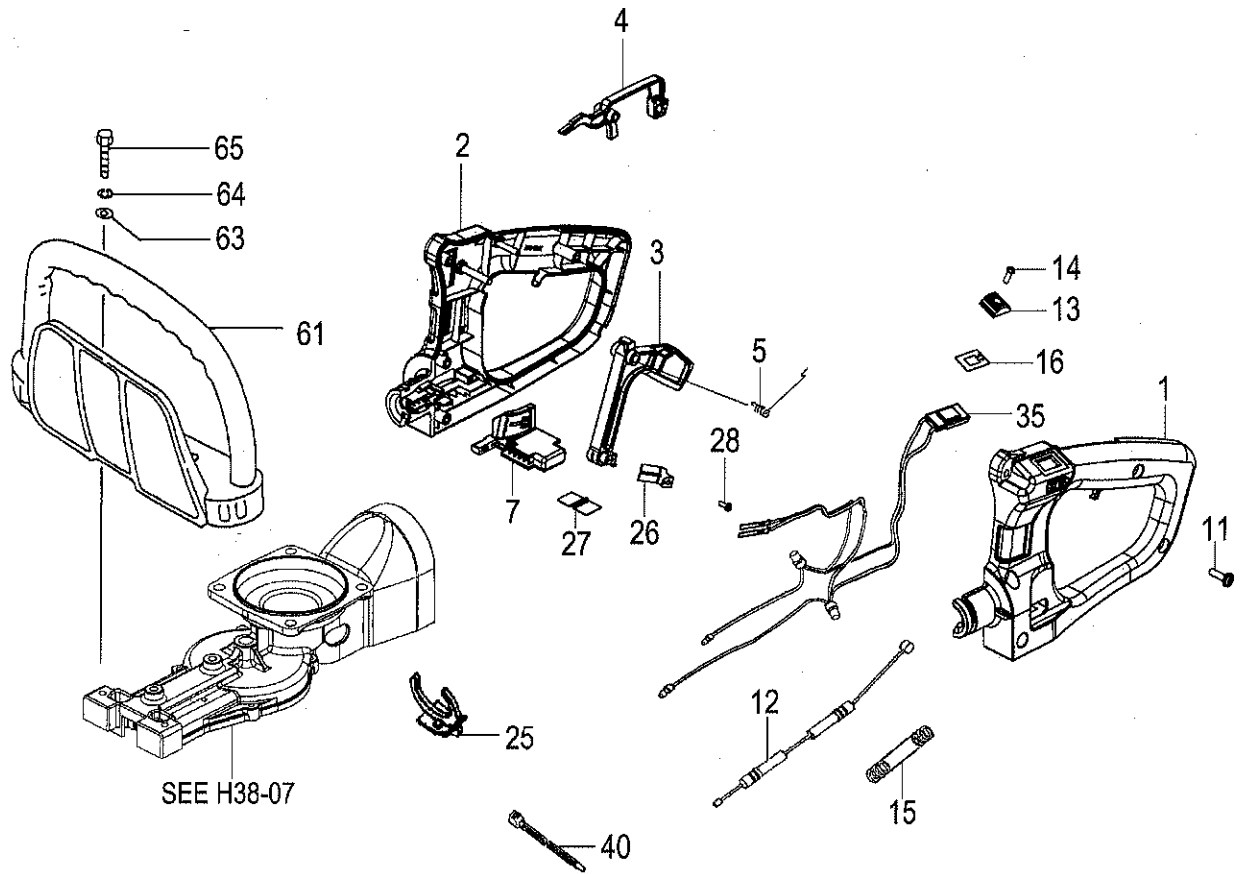

REF. NUMBER	PARTS NUMBER	DESCRIPTION	Q'TY	REMARKS /SERIAL NO.
H38-06 HANDLE				
001	668-6316	HANDLE B	1	
002	668-6280	HANDLE A	1	
003	668-8231	THROTTLE TRIGGER	1	
004	668-8240	SAFETY LEVER OR	1	
005	668-8244	THROTTLE LEVER SPRING	1	
007	668-8247	LOCK LEVER	1	
011	668-4636	TAPPING SCREW D4.5X16	5	
012	669-3990	THROTTLE WIRE	1	
013	668-8366	BUTTON STOP	1	
014	668-4913	SCREW 3X10	1	
015	668-7521	PROTECTION TUBE 130L	1	
016	669-4588	STOP BUTTON MARK	1	
025	669-1123	CLIP	1	
026	668-9130	EARTH TERMINAL	1	
027	668-8249	METAL PLATE	1	
028	668-5158	TAPPING SCREW D3X8	1	
035	668-7919	CORD COMP.	1	
040	668-8015	CORD CLAMP	1	
061	668-8096	FRONT HANDLE	1	
063	668-9680	BRAKE SHAFT WASHER	2	
064	668-4834	SPRING WASHER 5	2	
065	669-5054	HEX. HOLE BOLT 5X40	2	

H38-07 GEAR CASE/BLADE

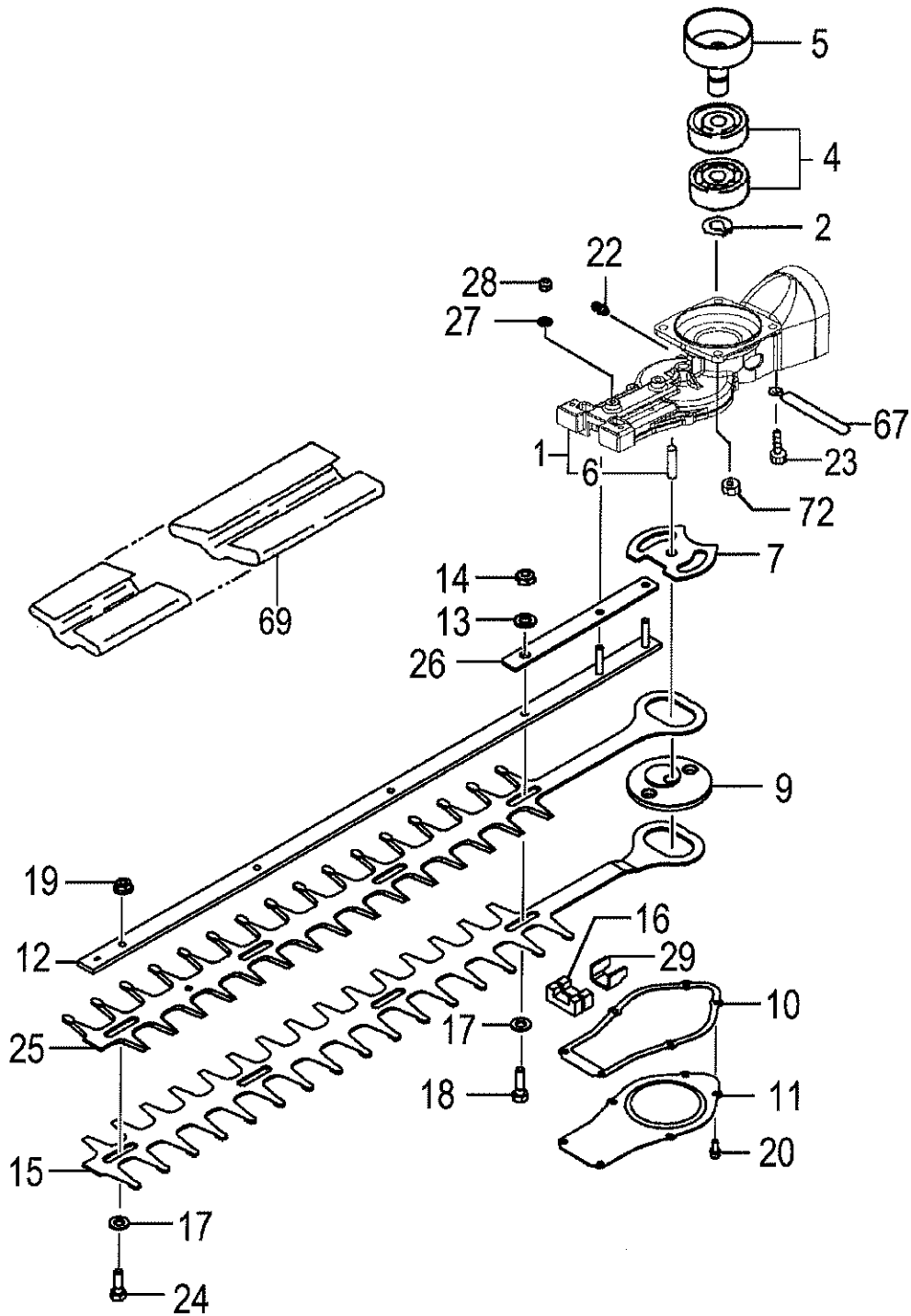

REF. NUMBER	PARTS NUMBER	DESCRIPTION	Q'TY	REMARKS /SERIAL NO.
H38-07 GEAR CASE/BLADE				
001	668-8826	GEAR CASE COMP	1	
002	669-5285	STOP RING C-15, OUTER	1	
004	669-5538	BALL BEARING #6002Z, 32MM/OD	2	
005	668-8570	CLUTCH DRUM COMP.	1	
006	668-8960	GEAR SHAFT	1	
007	668-6614	GUIDE PLATE	1	
009	668-8979	GEAR 2	1	
010	668-8909	GEAR CASE GASKET	1	
011	669-2102	GEAR CASE COVER	1	
012	668-7153	CUTTER GUIDE 680L	1	
013	668-4639	WASHER 6	1	
014	669-5175	NUT 6 UPS-P	1	
015	668-7120	CUTTER B 620L	1	
016	668-6658	GREASE SEAL A	2	
017	668-7187	WASHER 7 BLACK	5	
018	668-7158	FIXING BOLT A M6	1	
019	669-5170	FLANGE NUT 6	4	
020	669-5484	HEX. HOLE BOLT 4X10S	6	
022	668-8643	GREASE NIPPLE COMP.	1	
023	669-5495	HEX. HOLE BOLT 6X18/S	2	
024	668-7162	CUTTER FIXING BOLT B	4	
025	668-7096	CUTTER A 620L	1	
026	669-0761	SUPPORT PLATE	1	
027	668-4864	SMALL WASHER 5	2	
028	305-5491	NYLON NUT M5	2	
029	668-6468	HOLDING PLATE	1	
067	668-8008	CORD CLAMP COMP.	1	
069	668-7302	CUTTER COVER	1	
072	669-5475	SPRING NUT 6	2	

H38-08 TOOLS/LABELS

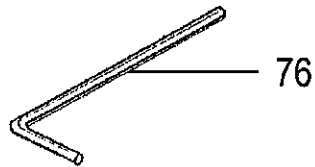
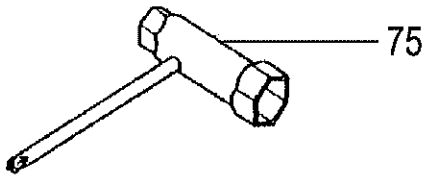
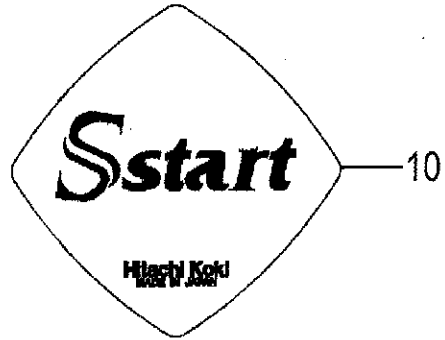

REF. NUMBER	PARTS NUMBER	DESCRIPTION	Q'TY	REMARKS
H38-08 TOOLS/LABELS				
001	669-4365	NAME PLATE CH62EA2(ST)	1	
010	669-4495	STARTER MARK S-START	1	
075	668-5997	COMBI. BOX SPANNER 10X19 ,PLU	1	
076	668-4813	HEX. BAR WRENCH 4MM	1	