

ELECTRIC TOOL PARTS LIST

■ DISC GRINDER
Model G 18UC

2012·12·18
(E1)

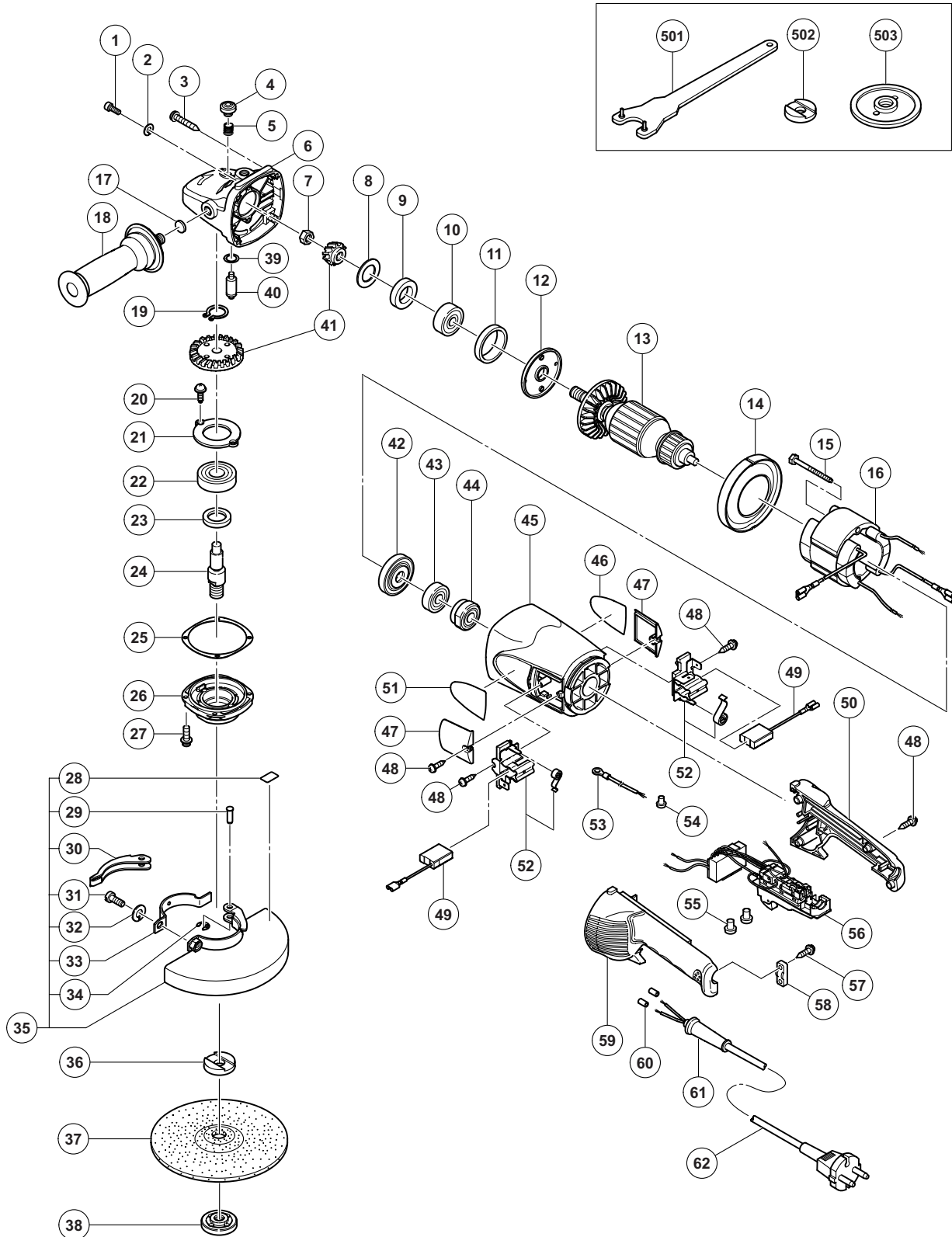

PARTS

G 18UC

ITEM NO.	CODE NO.	DESCRIPTION	NO. USED	REMARKS
1	984-509	SEAL LOCK HEX. SOCKET HD. BOLT M5 X 14	2	
2	949-454	SPRING WASHER M5 (10 PCS.)	2	
3	323-209	TAPPING SCREW (W/FLANGE) D5 X 35 (BLACK)	4	
4	306-888	PUSHING BUTTON	1	
5	320-219	SPRING	1	
6	320-217	GEAR COVER ASS'Y	1	INCLUD. 4, 5, 17, 39, 40
7	320-226	SPECIAL NUT M10	1	
8	320-221	SEAL WASHER	1	
9	320-222	FELT PACKING	1	
10	630-1DD	BALL BEARING 6301DDCMPS2L	1	
11	994-208	RUBBER RING (B)	1	
12	320-220	BEARING COVER (A)	1	
* 13	360-777E	ARMATURE 220 V-230 V	1	
* 13	360-594F	ARMATURE 240 V	1	
14	320-215	FAN GUIDE	1	
15	984-271	HEX. HD. TAPPING SCREW D5 X 75	2	
16	340-846E	STATOR 230 V-240 V	1	
17	937-033	FELT WASHER	1	
18	322-411	SIDE HANDLE	1	
19	939-542	RETAINING RING FOR D12 SHAFT (10 PCS.)	1	
20	949-236	MACHINE SCREW M5 X 10 (10 PCS.)	2	
21	320-229	BEARING COVER (B)	1	
22	630-2DD	BALL BEARING 6302DDCMPS2L	1	
23	990-852	FELT PACKING (B)	1	
24	320-234	SPINDLE	1	
25	320-228	SEAL PLATE	1	
26	320-227	PACKING GLAND	1	
27	994-192	HEX. SOCKET HD. BOLT (W/FLANGE) M5 X 16	4	
28	311-492	LABEL	1	
29	321-546	SET PIN	1	
30	321-545	LEVER	1	
31	306-887	BOLT M8 X 22	1	
32	949-457	SPRING WASHER M8 (10 PCS.)	1	
33	321-544	SET PIECE	1	
34	673-489	RETAINING RING (E-TYPE) FOR D5 SHAFT	1	
35	321-543	WHEEL GUARD ASS'Y	1	INCLUD. 28-34
* 36	937-908Z	WHEEL WASHER (B)	1	
* 36	937-907Z	WHEEL WASHER (C)	1	FOR NZL
37	316-824	D. C. WHEELS 180 MM A24R (25 PCS.)	1	
38	937-909Z	WHEEL NUT M14 X 2	1	
39	320-218	O-RING	1	
40	306-890	LOCK PIN	1	
41	330-032	GEAR AND PINION SET	1	
42	330-029	DUST SEAL	1	
43	600-0VV	BALL BEARING 6000VVCMP2L	1	
44	321-536	BEARING BUSHING	1	
45	321-535	HOUSING ASS'Y	1	INCLUD. 44
46		NAME PLATE	1	
47	320-232	BRUSH COVER	2	
48	305-812	TAPPING SCREW (W/FLANGE) D4 X 16 (BLACK)	8	

STANDARD ACCESSORIES

G 18UC

ITEM NO.	CODE NO.	DESCRIPTION	NO. USED	REMARKS
501	325-491	WRENCH	1	
502	937-907Z	WHEEL WASHER (C)	1	
503	937-917Z	WHEEL NUT (B)	1	

OPTIONAL ACCESSORIES

ITEM NO.	CODE NO.	DESCRIPTION	NO. USED	REMARKS
601	323-993	PIPE HANDLE SET	1	INCLUD. 602
602	985-597	BOLT M14	2	
603	310-337	SUPER WASHER	1	