

Tanaka

Parts Catalog

Brushcutter

Model: TBC-262

All Units After Serial Number G 231370

FIG. 1 ENGINE

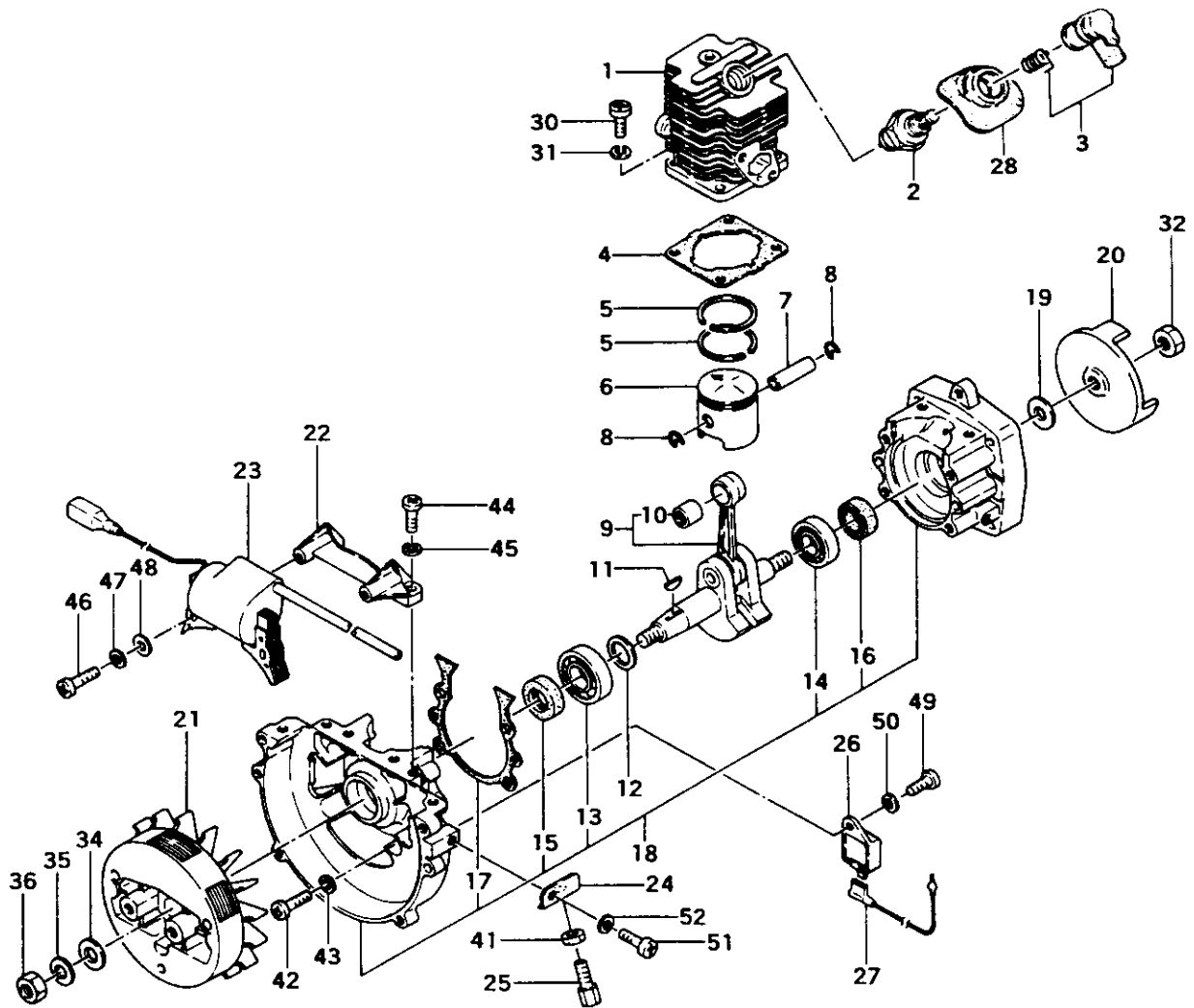

REF. NBR	PART NBR	PART NAME	QTY	SERIAL NBR	REMARKS
1-001	002-01601-800	CYLINDER COMP.	1		
1-002	018-00502-200	SPARK PLUG BM6A	1		
1-003	157-04000-900	SPARK PLUG CAP ASS'Y	1		
1-004	017-01620-200	CYLINDER GASKET	1		
1-005	041-01601-200	PISTON RING	2		
1-006	031-01601-200	PISTON	1		
1-007	037-01601-200	PISTON PIN	1		
1-008	039-01620-200	PISTON PIN CIRCLIP	2		
1-009	046-01620-801	CRANK SHAFT COMP.	1	M	
1-009	046-01620-800	CRANK SHAFT COMP.	1		
1-010	999-62081-225	NEEDLE BEARING F-810	1		
1-011	068-10100-200	WOOD-RUFF KEY 3X13X4.5	1		
1-012	071-02007-200	CRANK SHAFT SHIM 0.05	V		
1-012	071-02007-210	CRANK SHAFT SHIM 0.10	V		
1-012	071-02007-220	CRANK SHAFT SHIM 0.15	V		
1-012	071-02007-230	CRANK SHAFT SHIM 0.20	V		
1-012	071-02007-240	CRANK SHAFT SHIM 0.30	V		
1-013	999-61600-200	BALL BEARING #6002. 32MM/OD	1		
1-014	999-61600-100	BALL BEARING #6001. 28MM/OD	1		
1-015	999-66152-500	OIL SEAL 15257	1		
1-016	999-66122-266	OIL SEAL 12227	1		
1-017	090-00601-205	CRANK CASE GASKET	1		
1-018	072-01620-900	CRANK CASE ASS'Y	1		
1-019	359-10112-203	CLUTCH WASHER B	1		
1-020	798-01620-200	STARTER PULLEY	1		
1-021	155-21720-800	MAGNETO ROTOR COMP.	1	R	-D149567
1-021	155-21720-801	MAGNETO ROTOR COMP.	1	R	-E073890
1-021	155-21720-802	MAGNETO ROTOR COMP.	1		E073891-
1-022	165-01620-200	IGNITION COIL BRACKET	1	I	-F141220
1-022	165-0162V-200	IGNITION COIL BRACKET	1		F141221-
1-023	167-20757-801	IGNITION COIL COMP.	1	I	-D114148
1-023	167-21507-802	IGNITION COIL COMP	1		D114149-
1-024	904-01620-200	ADJUSTER BRACKET	1		-E244275
1-024	904-01620-201	ADJUSTER BRACKET	1	P	E244276-
1-025	894-01401-201	OUTER RECEIVER	1		
1-026	159-21401-872	IGNITOR COMP. TT1-1F	1		
1-027	173-0162R-800	IGNITOR LEAD WIRE COMP., R85M	1		
1-028	255-0608A-200	SPARK PLUG RUBBER COVER	1	N	D170956-
1-030	990-11050-161	SCREW 5X16	4		
1-031	992-10050-012	S. WASHER 5	4		
1-032	991-01080-011	HEX. NUT 8	1		
1-034	992-00080-011	SMALL WASHER 8	1		
1-035	992-10080-012	S. WASHER 8	1		
1-036	991-01080-011	HEX. NUT 8	1		
1-041	991-01060-013	NUT 6	1		
1-042	990-11050-301	SCREW 5X30	4		
1-043	992-10050-012	S. WASHER 5	4		
1-044	990-11050-161	SCREW 5X16	2		
1-045	992-10050-012	S. WASHER 5	2		
1-046	990-11040-181	SCREW 4X18	2		
1-047	992-10040-012	S. WASHER 4	2		
1-048	992-00040-011	SMALL WASHER 4	2		
1-049	990-11040-081	SCREW 4X8	1		
1-050	992-10040-012	S. WASHER 4	1		
1-051	990-11050-121	SCREW 5X12	1		
1-052	992-10050-012	S. WASHER 5	1		

FIG.2 ENGINE COMPONENTS

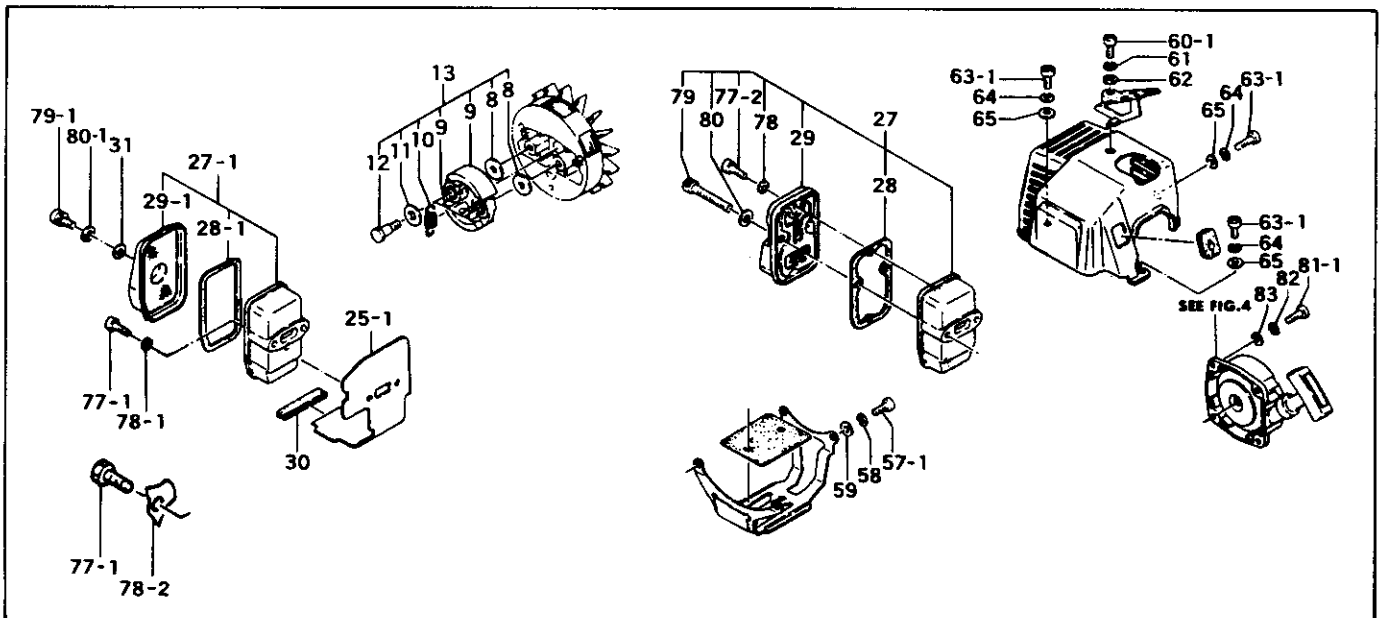
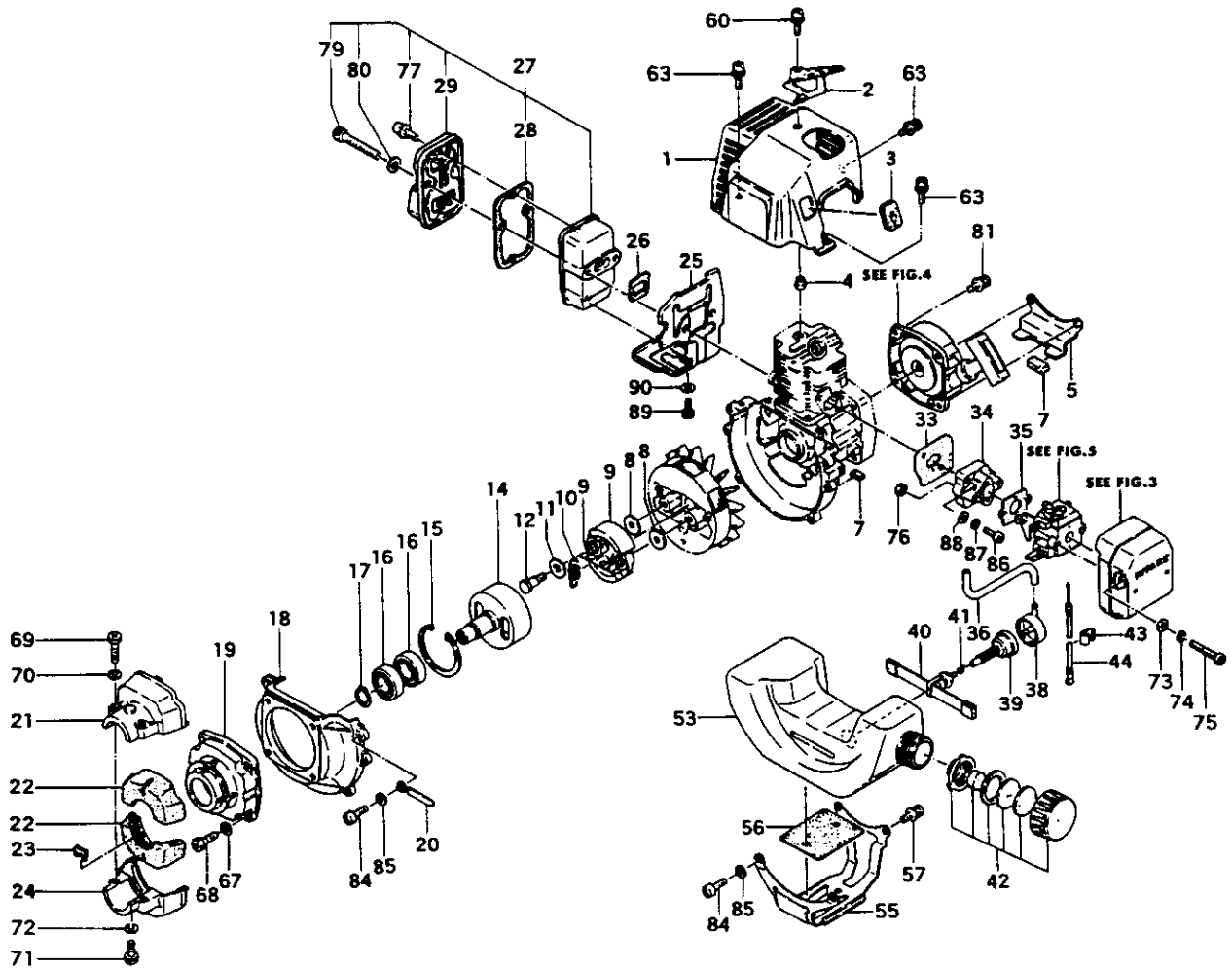

REF. NBR	PART NBR	PART NAME	QTY	UNIT	SERIAL NBR	REMARKS
2-001	738-01620-200	MUFFLER PROTECTOR	1	R	-D149567	
2-001	738-01620-201	MUFFLER PROTECTOR	1		D149568-	
2-002	257-0630B-201	SPARK PLUG COVER	1		-D074939	
2-002	257-0630B-210	SPARK PLUG COVER	1	P	D074940-	
2-003	203-0630B-200	PRIMARY CORD GROMMET	1		-D074939	
2-003	203-0630B-201	PRIMARY CORD GROMMET	1	P	D074940-	
2-004	011-01620-200	CYLINDER COVER COLLAR	1			
2-005	653-01620-200	TANK BRACKET	1			
2-007	655-06100-200	FUEL TANK CUSHION RUBBER	4			
2-008	359-02103-200	CLUTCH WASHER B	2			
2-009	290-01620-800	CLUTCH SHOE COMP.	2			
2-010	342-0630B-200	CLUTCH SPRING	1			
2-011	358-02103-200	WASHER	2			
2-012	357-0075T-200	STEP BOLT	2			
2-013	277-01620-900	CLUTCH ASS'Y	1	M		
2-014	289-01620-800	CLUTCH SHAFT COMP.	1			
2-015	993-51032-002	STOP RING C-32 IN	1			
2-016	999-61600-201	BALL BEARING #6002ZZ. 32MM/OD	2			
2-017	993-50015-002	STOP RING C-15 EX	1			
2-018	112-01620-200	FAN CASE	1			
2-019	331-01620-200	CLUTCH CASE	1			
2-020	198-01046-900	CORD CLAMP ASS'Y	1	I	-F141220	
2-020	198-05015-800	CORD CLAMP COMP.	1		F141221-	
2-021	538-01620-200	ANTI-VIBE CASE A	1	R	-F001500	
2-021	538-01620-201	ANTI-VIBE CASE A	1		F001501-	
2-022	599-01620-200	CUSHION RUBBER	2			
2-023	176-01620-200	EARTH TERMINAL	1			
2-024	539-01620-200	ANTI-VIBE CASE B	1	R	-F001500	
2-024	539-01620-201	ANTI-VIBE CASE B	1		F001501-	
2-025, 1	133-01620-200	HEAT SHIELD	1	M		
2-025, 1	133-01620-201	HEAT SHIELD	1		-D149567	
2-025, 1	133-01620-202	HEAT SHIELD	1	M		
2-025	133-01620-210	HEAT SHIELD	1	N	D149568-	
2-026	737-01620-200	MUFFLER GASKET	1	N	D149568-	
2-027, 1	705-01620-902	MUFFLER ASS'Y	1	R	-D149567	
2-027	705-01620-910	MUFFLER ASS'Y	1		D149568-	
2-028, 1	739-01620-200	MUFFLER GASKET	1		-D149567	
2-028	739-01620-210	MUFFLER COUPLING GASKET	1	N	D149568-	
2-029, 1	717-01620-800	MUFFLER BODY B COMP.	1		-D149567	
2-029	717-01620-810	MUFFLER BODY B COMP.	1	N	D149568-	
2-030	599-0602K-201	CUSHION RUBBER	1	D	D149568-	
2-031	102-01300-200	INSULATOR	1	D	D149568-	
2-033	403-01620-200	INLET MANIFOLD GASKET	1			
2-034	404-01620-801	CARBURETOR INSULATOR COMP.	1			
2-035	402-00601-202	CARBURETOR GASKET	1			
2-036	700-03005-150	FUEL PIPE 3X5X150	1			
2-038	500-33202-205	RUBBER PIPE CAP	1			
2-039	678-00601-201	RUBBER PIPE	1			
2-040	675-0608A-900	PUMP FILTER BODY ASS'Y	1			
2-041	680-04019-210	CLIP 7	1	M		
2-041	680-00731-201	CLIP	1			
2-042	595-0062A-910	TANK CAP ASS'Y, ORANGE	1	M		
2-042	595-0062A-901	TANK CAP ASS'Y	1			
2-043	778-36100-200	CORD CLAMP	1			
2-044	885-0162R-800	THROTTLE WIRE COMP.	1			
2-053	591-01620-200	FUEL TANK	1	R	-D149567	
2-053	591-01620-201	FUEL TANK	1		D149568-	
2-055	941-01620-200	STAND	1	N	E306501-	
2-056	652-04200-200	CUSHION RUBBER	1	N	E306501-	
2-057, 1	990-11040-141	SCREW 4X14	2		-E306500	
2-057, 1	990-11040-161	SCREW 4X16	2	M		
2-057	994-15040-162	SCREW 4X16/PS	2	N	E306501-	
2-058	992-10040-012	S.WASHER 4	2	D	E306501-	

- To be cont'd -

REF. NBR	PART NBR	PART NAME	QTY	SERIAL NBR	REMARKS
2-059	992-01040-011	WASHER 4	2	D E306501-	
2-060.1	990-11050-221	SCREW 5X22	1	M	
2-060	994-15050-222	SCREW 5X22/PS	1		
2-061	992-10050-012	S.WASHER 5	1	M	
2-062	992-01050-011	WASHER 5	1	M	
2-063.1	990-11050-121	SCREW 5X12	3	M	
2-063	994-15050-122	SCREW 5X12/PS	3		
2-064	992-10050-012	S.WASHER 5	3	M	
2-065	992-01050-011	WASHER 5	3	M	
2-067	992-10060-012	S.WASHER 6	4		
2-068	990-31060-181	BOLT 6X18	4	M	
2-068	990-33060-181	BOLT 6X18	4		
2-069	990-21060-251	BOLT 6X25	2	M	
2-069	990-21060-221	BOLT 6X22	2		-G065501
2-069	990-23060-221	BOLT 6X22 W/PLUS	2	P	G065502-
2-070	992-10060-012	S.WASHER 6	2		
2-071	990-11050-121	SCREW 5X12	1		
2-072	992-10050-012	S.WASHER 5	1	N	G065502-
2-073	992-00050-011	SMALL WASHER 5	2		
2-074	992-10050-012	S.WASHER 5	2		
2-075	990-11050-601	SCREW 5X60	2		
2-076	991-01050-011	HEX. NUT 5	2	R	-E244275
2-076	991-74050-010	U-NUT 5	2		E244276-
2-077.1	990-23050-156	BOLT 5X15	2		-D149567
2-077.2	990-11040-121	SCREW 4X12	2	M	
2-077	994-13040-122	SCREW 4X12/P	2	N	D149568-
2-078.1	992-10050-012	S.WASHER 5	2		-D149567
2-078.2	200-01620-200	LOCK WASHER	2	N	D149568-
2-078.2	200-01620-200	LOCK WASHER	2	D	D149568-
2-078	992-01040-011	WASHER 4	2	M	
2-079.1	994-14060-152	SCREW 6X15/S	2		-D149567
2-079	990-51050-453	HEX. HOLE BOLT 5X45	2	N	D149568-
2-080.1	992-01060-061	WASHER 6	2		-D149567
2-080	992-01050-061	WASHER 5	2	N	D149568-
2-081.1	990-11040-141	SCREW 4X14	2	M	
2-081	994-15040-142	SCREW 4X14/PS	2		
2-082	992-10040-012	S.WASHER 4	2	M	
2-083	992-01040-011	WASHER 4	2	M	
2-084	990-11050-161	SCREW 5X16	4		
2-085	992-10050-012	S.WASHER 5	4		
2-086	990-11050-221	SCREW 5X22	2		
2-087	992-10050-012	S.WASHER 5	2		
2-088	992-00050-011	SMALL WASHER 5	2		
2-089	990-11050-101	SCREW 5X10	1	N	D149568-
2-090	992-01050-011	WASHER 5	1	N	D149568-

FIG.3 AIR CLEANER

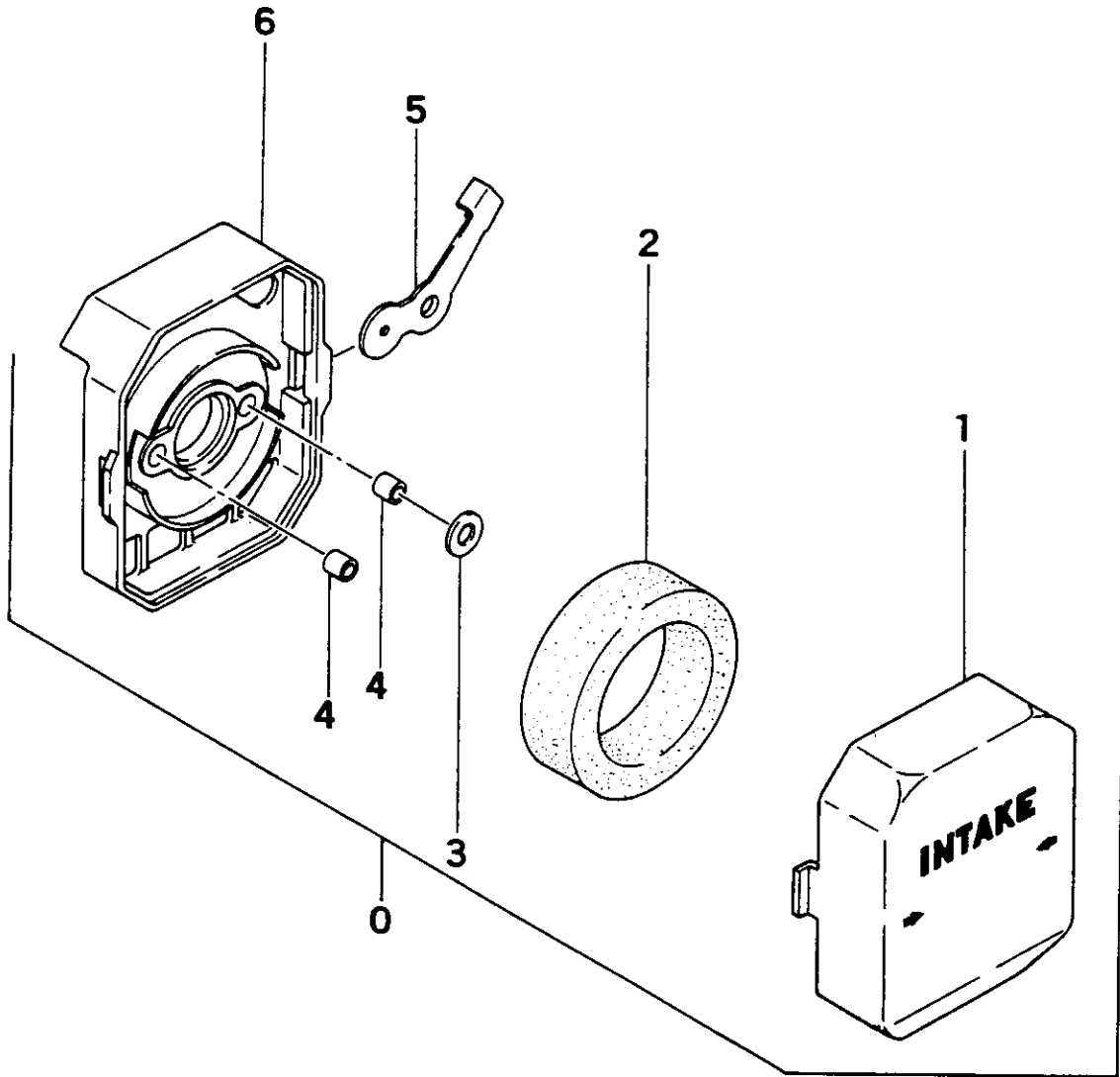

REF. NBR	PART NBR	PART NAME	QTY	SERIAL NBR	REMARKS
3-000	410-0602D-900	AIR CLEANER ASS'Y	1	R -D114148	
3-000	410-0602D-901	AIR CLEANER ASS'Y	1	D114149-	
3-001	424-0602K-200	AIR CLEANER CAP	1	R -D114148	
3-001	424-0602K-201	AIR CLEANER CAP	1	D114149-	
3-002	446-0602K-200	CLEANER ELEMENT	1		
3-003	453-0602K-200	SPACER	1		
3-004	470-0602K-200	COLLAR	2		
3-005	528-0602D-200	CHOKE PLATE.W/2MM HOLE	1		
3-006	423-0602K-200	CLEANER BODY	1	-D114148	
3-006	423-0602K-210	CLEANER BODY	1	N D114149-	

FIG.4 RECOIL STARTER

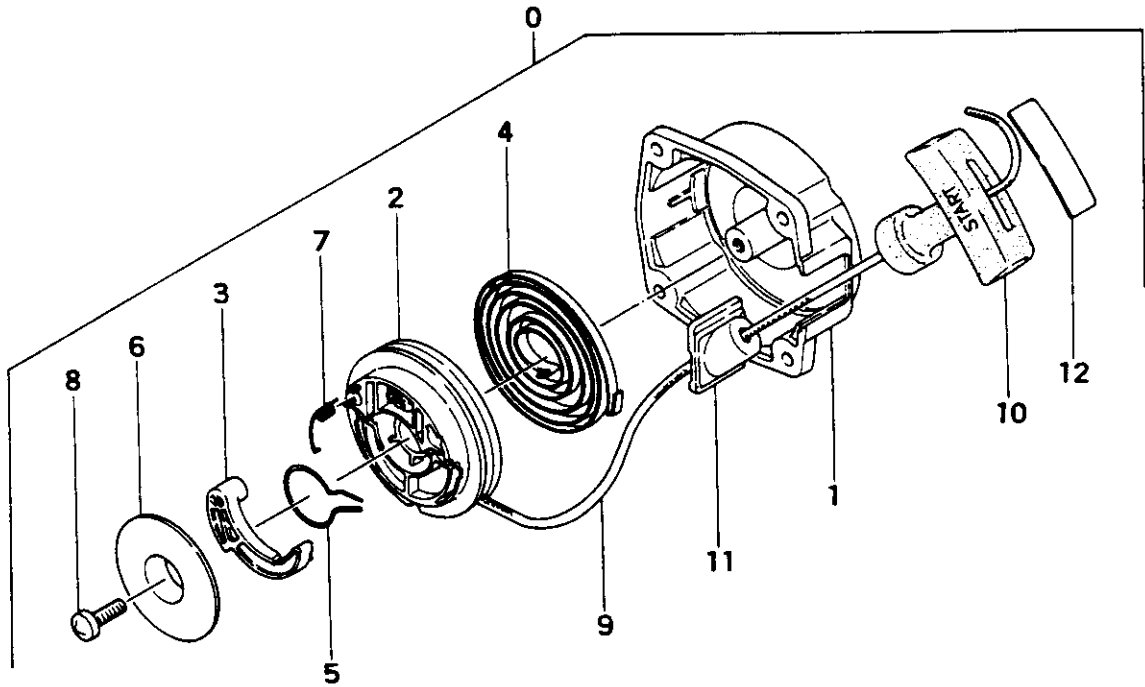

REF. NBR	PART NBR	PART NAME	QTY	SERIAL NBR	REMARKS
4-000	762-01620-900	RECOIL STARTER BODY ASS'Y	1		
4-001	772-06150-200	RECOIL STARTER BODY	1		
4-002	769-01250-200	STARTER ROPE REEL	1		
4-003	788-01250-200	STARTER PAWL	1		
4-004	779-01250-200	RECOIL SPRING	1		
4-005	836-01250-200	FRICTION SPRING	1	M	
4-005	836-06092-200	FRICTION SPRING	1		
4-006	837-01250-200	FRICTION PLATE	1	M	
4-006	837-06092-200	FRICTION PLATE	1		
4-007	832-01250-200	RETURN SPRING	1		
4-008	990-15050-121	SCREW 5X12	1		
4-009	783-06092-200	ROPE 3.5X890L	1	M	
4-009	783-06150-200	ROPE 3.5X890L	1	M	
4-009	783-0162V-200	ROPE 3.5X890	1		
4-010	785-01620-200	STARTER HANDLE	1		
4-011	780-06150-200	ROPE GUIDE	1		
4-012	795-01620-200	HANDLE KNOB SEAL	1		

FIG.5 CARBURETOR

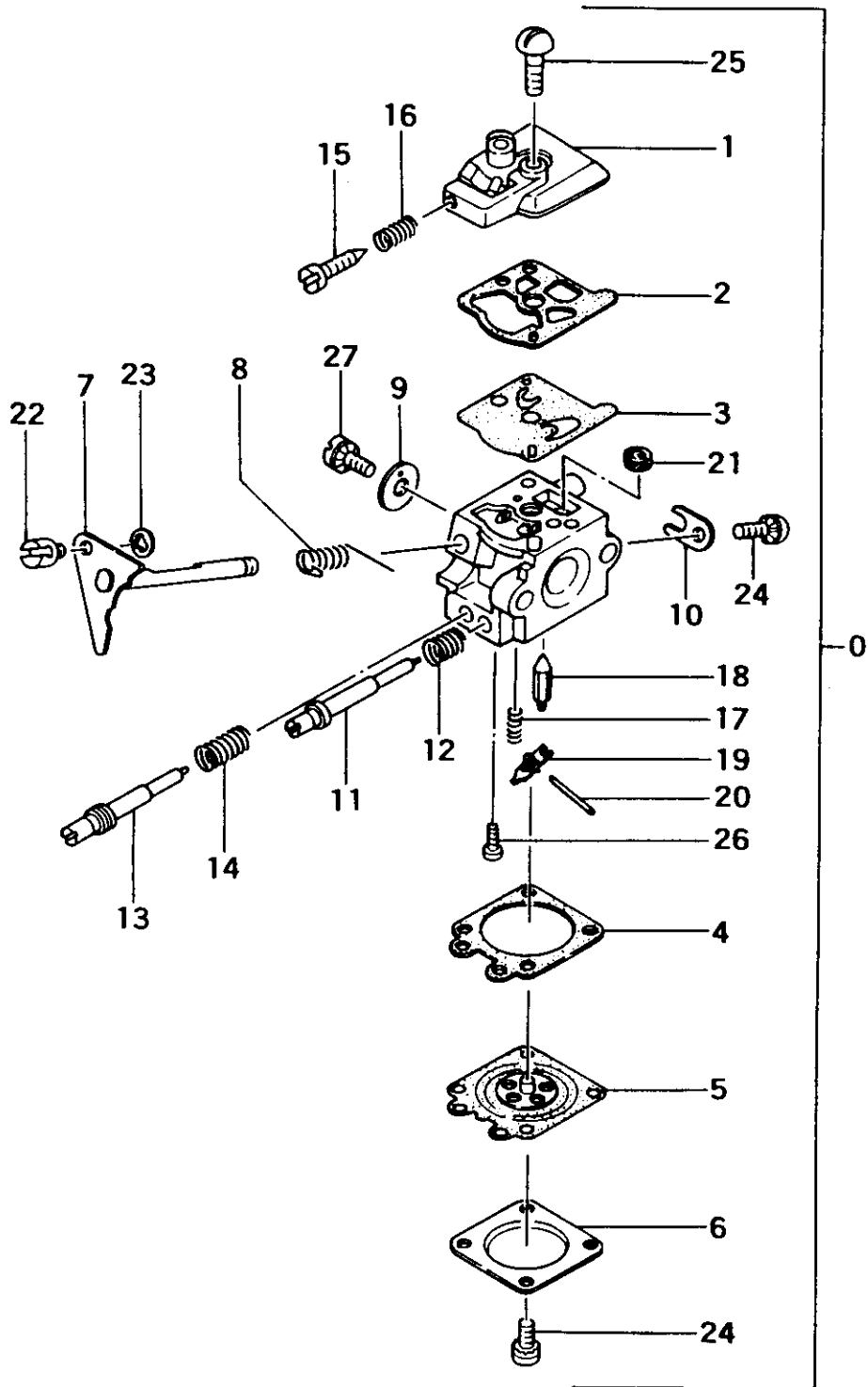

REF. NBR	PART NBR	PART NAME	QTY	SERIAL NBR	REMARKS
5-000	455-25023-900	CARBURETOR ASS'Y WA-164	1		
5-001	575-25010-200	PUMP BODY	1		
5-002	577-25007-200	PUMP GASKET	1		
5-003	576-25006-200	PUMP DIAPHRAGM	1		
5-004	475-25001-200	DIAPHRAGM GASKET	1		
5-005	474-25001-800	METERING DIAPHRAGM COMP.	1		
5-006	476-25006-200	DIAPHRAGM COVER	1	M	
5-006	476-25004-200	DIAPHRAGM COVER	1		
5-007	464-25010-800	THROTTLE SHAFT COMP.	1		
5-008	486-25006-200	THROTTLE SPRING	1	M	
5-008	486-25009-200	THROTTLE SPRING	1		
5-009	488-25080-200	THROTTLE VALVE	1	M	
5-009	488-25008-200	THROTTLE VALVE	1		
5-010	557-25006-200	THROTTLE SHAFT CLIP	1		
5-011	460-25023-200	HIGH ADJUST SCREW	1		
5-012	485-25003-200	HIGH ADJUST SPRING	1		
5-013	461-25023-200	LOW ADJUST SCREW	1		
5-014	623-25001-200	HIGH/LOW ADJUST SPRING	1		
5-015	462-25006-200	IDLE ADJUST SCREW	1		
5-016	463-25006-200	IDLE ADJUST SPRING	1		
5-017	477-25007-200	VALVE SPRING	1		
5-018	603-25001-200	NEEDLE VALVE	1		
5-019	473-25001-200	VALVE HINGE	1		
5-020	605-25001-200	HINGE PIN	1		
5-021	578-25006-200	INLET SCREEN	1	M	
5-021	578-25007-200	INLET SCREEN	1		
5-022	539-25006-200	SWIVEL	1	M	
5-022	539-25008-200	SWIVEL	1		
5-023	489-25006-200	STOP RING	1	M	
5-023	489-25008-200	STOP RING	1		
5-024	548-25014-200	SET SCREW	5	M	
5-024	548-25012-200	SET SCREW	5		
5-025	514-25001-200	SET SCREW	1		
5-026	546-25001-200	HINGE PIN SET SCREW	1		
5-027	467-25003-200	SHUTTER SCREW	1		

FIG.6 HANDLE

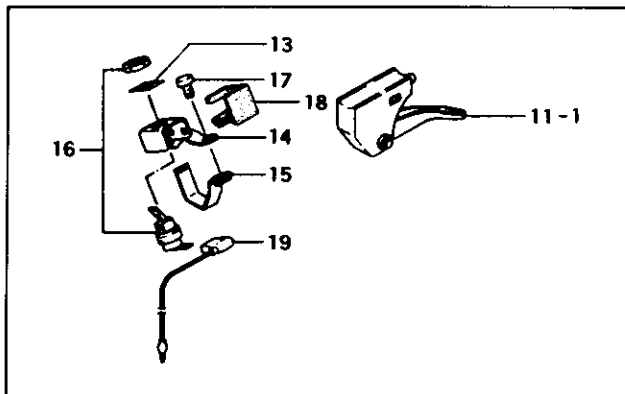
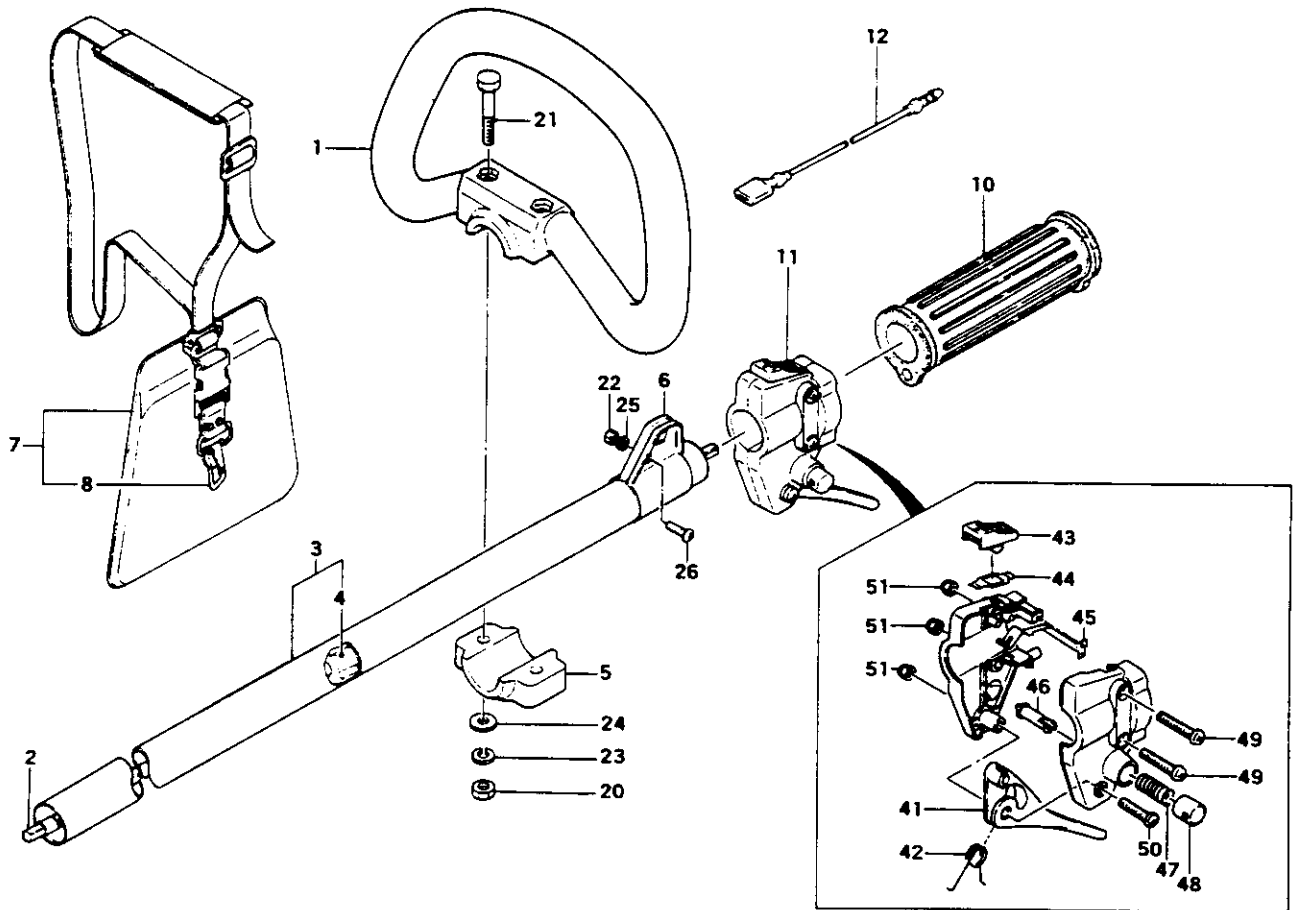

REF. NBR	PART NBR	PART NAME	QTY	SERIAL NBR	REMARKS
6-001	500-33560-200	HANDLE	1		
6-002	343-37000-200	DRIVE SHAFT	1		
6-003	341-33560-801	DRIVE SHAFT PIPE COMP.	1		
6-004	347-33411-912	BUSHING ASS'Y	5		
6-005	506-33560-200	HANDLE BRACKET A	1		
6-006	335-33410-200	LIFTING METAL	1		
6-007	746-33564-900	SHOULDER BELT ASSY, KOREAN MAKE	1		
6-008	748-33564-900	HOOK ASS'Y	1	N E244276-	
6-010	504-33412-200	SHAFT GRIP	1		
6-011, 1	870-0062M-900	THROTTLE LEVER ASS'Y	1	N	
6-011, 1	870-00741-900	THROTTLE LEVER ASS'Y	1	-D149567	
6-011	870-33564-900	THROTTLE LEVER ASS'Y	1	N -E244275	
6-011	870-33564-901	THROTTLE LEVER ASS'Y	1	P E244276-	
6-012	178-37003-800	STOP CORD COMP.	1	N D149568-	
6-013	183-01300-200	SWITCH NAME PLATE	1	D D149568-	
6-014	640-33905-200	STOP BUTTON BRACKET	1	D D149568-	
6-015	883-33564-800	THROTTLE LEVER BAND COMP.	1	D D149568-	
6-016	162-01300-900	STOP SWITCH ASS'Y	1	D D149568-	
6-017	990-11050-141	SCREW 5X14	1	D D149568-	
6-018	168-33905-201	STOP BUTTON COVER	1	D D149568-	
6-019	178-0162R-800	STOP CORD COMP.	1	D D149568-	
6-020	991-01060-011	NUT 6	2		
6-021	990-21060-451	BOLT 6X45	2		
6-022	991-01050-011	HEX. NUT 5	1		
6-023	992-10060-012	S. WASHER 6	2		
6-024	992-01060-011	WASHER 6	2		
6-025	992-10050-012	S. WASHER 5	1		
6-026	990-11050-161	SCREW 5X16	1		
6-041	880-33564-200	THROTTLE ARM	1	N D149568-	
6-042	832-33564-200	RETURN SPRING	1	N D149568-	
6-043	162-33564-200	STOP SWITCH	1	N D149568-	
6-043	162-33564-200	STOP SWITCH	1	-E244275	
6-043	162-33564-210	STOP SWITCH	1	N E244276-	
6-044	262-33564-200	STOP SWITCH SPRING	1	N D149568-	
6-045	176-33564-200	EARTH TERMINAL	1	N D149568-	
6-046	956-33564-200	LOCK BUTTON A	1	N D149568-	
6-047	958-33564-200	LOCK BUTTON SPRING	1	N D149568-	
6-048	957-33564-200	LOCK BUTTON B	1	N D149568-	
6-049	990-11050-301	SCREW 5X30	2	N D149568-	
6-049	990-11050-301	SCREW 5X30	2	-F141220	
6-049	994-31050-301	SCREW 5X30	2	P F141221-	
6-050	994-31050-251	SCREW 5X25	1	N D149568-	
6-051	991-86050-000	SELF-LOCK NUT 5	3	N D149568-	

FIG.7 GEAR CASE

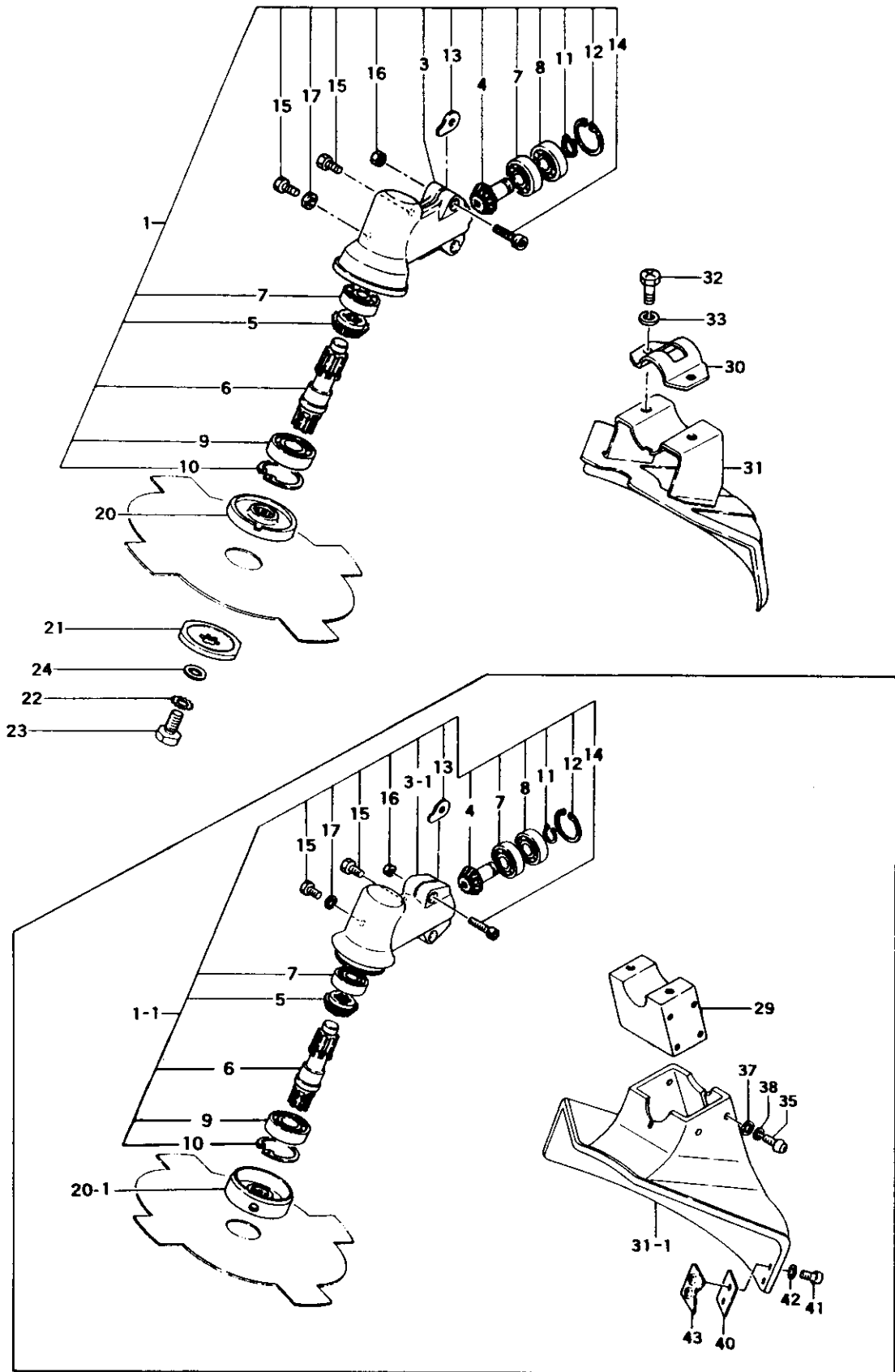

REF. NBR	PART NBR	PART NAME	QTY	SERIAL NBR	REMARKS
7-001, 1	300-37000-900	GEAR CASE ASS'Y	1	-D149567	
7-001	300-37000-910	GEAR CASE ASS'Y	1	N -E244275	
7-001	300-37000-910	GEAR CASE ASS'Y	1	R -E244275	
7-001	300-37000-911	GEAR CASE ASS'Y	1	R -G230370	
7-001	300-37000-912	GEAR CASE ASS'Y	1	G230371-	
7-003, 1	300-33410-201	GEAR CASE	1	-D149567	
7-003	300-33410-210	GEAR CASE	1	N -E244275	
7-003	300-33410-210	GEAR CASE	1	R -E244275	
7-003	300-33410-211	GEAR CASE	1	R -G230370	
7-003	300-33410-212	GEAR CASE	1	G230371-	
7-004	302-37000-200	PINION	1		
7-005	301-33411-200	GEAR	1		
7-006	304-37000-200	GEAR SHAFT	1		
7-007	999-61600-000	BALL BEARING #6000, 26MM/OD	2		
7-008	999-61600-004	BALL BEARING #6000DD, 26MM/OD	1	I -F141220	
7-008	999-61600-003	BALL BEARING 6000D, 26MM/OD	1	F141221-	
7-009	999-61600-204	BALL BEARING #6002DD, 32MM/OD	1	I -F141220	
7-009	999-61600-203	BALL BEARING 6002D, 32MM/OD	1	F141221-	
7-010	993-51032-002	STOP RING C-32 IN	1		
7-011	993-50010-002	STOP RING C-10 EX	1		
7-012	993-51026-002	STOP RING C-26 IN	1		
7-013	324-33410-201	GEAR CASE WASHER	2		
7-014	990-51050-203	HEX. HOLE BOLT 5X20	2		
7-015	990-23080-121	BOLT 6X12 W/PLUS	2		
7-016	991-01050-011	HEX. NUT 5	2		
7-017	317-33411-201	OILING GASKET	1		
7-020, 1	310-33410-202	CUTTER HOLDER	1	-D149567	
7-020	310-33524-201	CUTTER HOLDER	1	N -G230370	
7-020	310-33524-201	CUTTER HOLDER	1	R -G230370	
7-020	310-33524-202	CUTTER HOLDER	1	G230371-	
7-021	311-33411-201	CUTTER HOLDER CAP	1		
7-022	992-29080-000	TOOTHED LOCK WASHER 8 L/H	1		
7-023	312-33411-200	CUTTER FIXING BOLT/L.H.T.	1		
7-024	992-01080-011	WASHER 8	1		
7-029	445-33578-200	SAFETY GUARD HOLDER	1	D D149568-	
7-030	442-33671-200	SAFETY GUARD BRACKET	1	R -D149567	
7-030	442-33671-201	SAFETY GUARD BRACKET	1	D149568-	
7-031, 1	441-33671-200	SAFETY GUARD	1	-D149567	
7-031	441-37003-800	SAFETY GUARD COMP., METAL	1	N D149568-	
7-031	441-37003-800	SAFETY GUARD COMP., METAL	1	R -E244275	
7-031	441-37003-801	SAFETY GUARD COMP., METAL	1	E244276-	
7-032	990-23080-151	BOLT 6X15 W/PLUS	2		
7-033	992-10060-012	S. WASHER 6	2		
7-035	990-11050-161	SCREW 5X16	4	D D149568-	
7-037	992-01050-011	WASHER 5	4	D D149568-	
7-038	992-10050-012	S. WASHER 5	4	D D149568-	
7-040	800-33005-201	CORD CUTTER BLADE	1	D D149568-	
7-041	990-11040-121	SCREW 4X12	2	D D149568-	
7-042	992-01040-011	WASHER 4	2	D D149568-	
7-043	799-33005-200	BLADE GUIDE	1	D D149568-	

FIG.8 TOOLS & NYLON HEAD

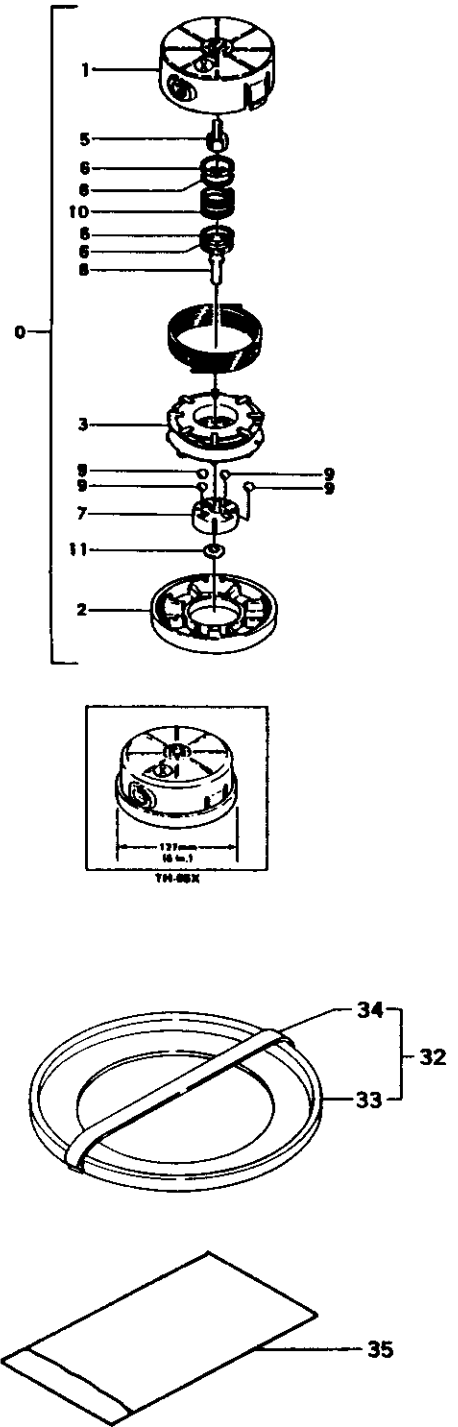
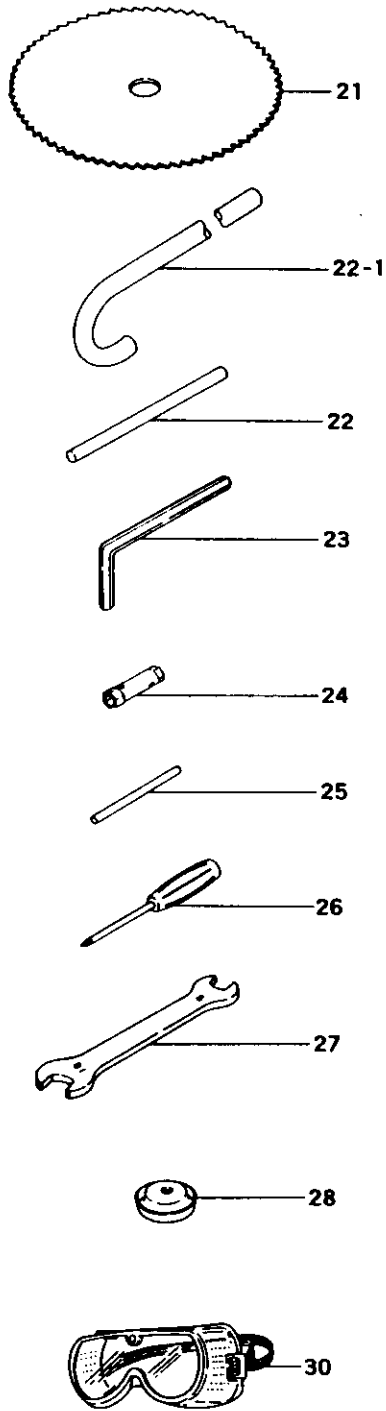

REF. NBR	PART NBR	PART NAME	QTY	SERIAL NBR	REMARKS
8-000	783-33440-901	NYLON HEAD ASS'Y (TH-95X)	1		
8-001	786-33004-801	CUTTING BODY COMP.	1		
8-002	789-33004-201	BODY CAP	1		
8-003	787-33004-202	CORD REEL	1		
8-005	314-33670-200	8X1.25 L/H BOLT (GOLD)	1		
8-006	792-33004-200	REEL WASHER	4		
8-007	790-33004-200	REEL SLIDER	1		
8-008	791-33004-200	REEL SLIDER HOOK	1		
8-009	673-35600-200	STEEL BALL 5/16"	4		
8-010	793-33440-200	REEL SPRING (GOLD)	1		
8-011	358-02103-200	WASHER	1		
8-021	809-33441-200	BLADE 80 TEETH 230	1	D	D149568-
8-022, 1	752-33564-201	CUTTER HOLDER STOPPER	1		-D149567
8-022	752-33900-200	LOCKING BAR	1	N	D149568-
8-023	813-20000-200	HEX. WRENCH 4	1		
8-024	826-20000-200	BOX SPANNER 17X19	1		
8-025	951-20000-200	HANDLE 8X120	1		
8-026	862-20000-200	PLUS DRIVER 4	1		
8-027	801-20000-200	SPANNER 8X10	1		
8-028	316-33410-200	BOLT PROTECTION COVER	1		
8-030	540-33671-900	GOGGLE ASS'Y	1		
8-032	615-33411-900	CUTTER COVER ASS'Y	1		
8-033	615-33411-200	CUTTER COVER	1		
8-034	616-33411-200	CUTTER COVER BAND	1		
8-035	948-32310-200	TOOL BAG	1	I	-G006000
8-035	948-39907-200	TOOL BAG	1		G006001-

FIG.9 MARKS

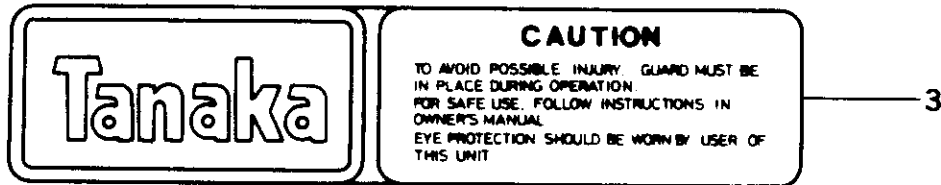
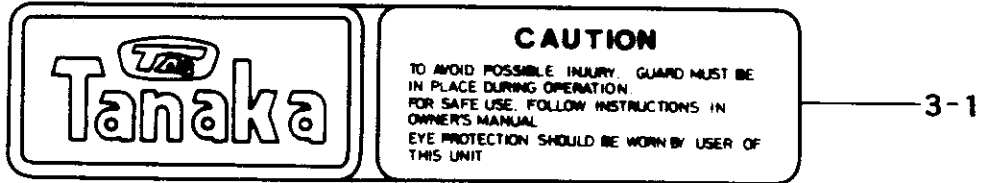
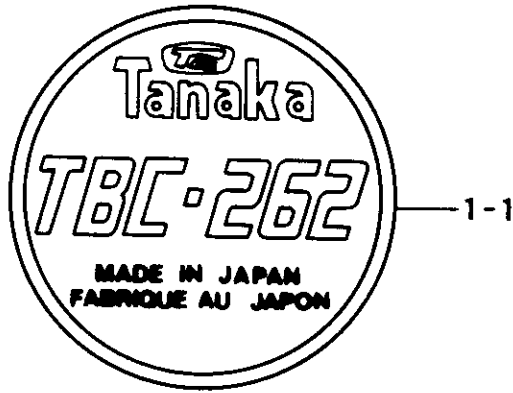

REF. NBR	PART NBR	PART NAME	QTY	SERIAL NBR	REMARKS
9-001,1	906-0162R-200	NAME PLATE	1 R	-F206250	
9-001	906-0162R-210	NAME PLATE	1	F206251-	
9-002,1	929-0608A-200	SYMBOL MARK	1 R	-F141220	
9-002	929-0608A-201	SYMBOL MARK	1	F141221-	
9-003,1	929-33576-200	SYMBOL MARK	1 R	-G230370	
9-003	929-33576-201	SYMBOL MARK	1	G230371-	
9-004	923-33700-200	LEVEL MARK	1		
9-005	926-37000-200	GEAR CASE MARK	1 D	E244276-	