

ELECTRIC TOOL PARTS LIST

CORDLESS IMPACT DRIVER Model WH 18DDL

2013-2-4
(E1)

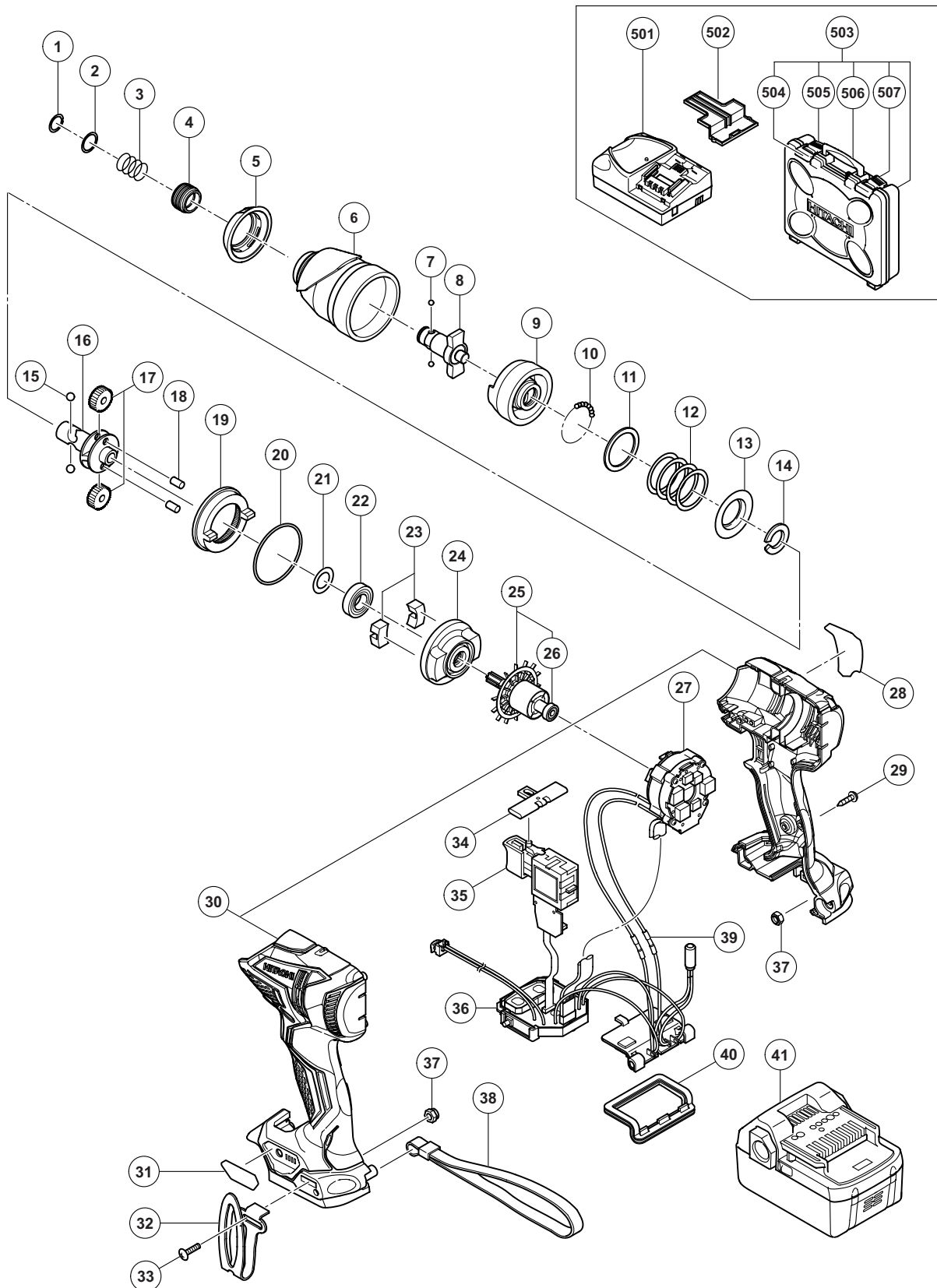

PARTS

WH 18DDL

ITEM NO.	CODE NO.	DESCRIPTION	NO. USED	REMARKS
1	315-984	RETAINING RING	1	
2	330-856	WASHER (D)	1	
3	321-657	GUIDE SPRING (D)	1	
4	335-315	GUIDE SLEEVE (F)	1	
5	335-330	FRONT CAP	1	
6	335-331	HAMMER CASE	1	
7	319-535	STEEL BALL D3.5 (10 PCS.)	2	
* 8	335-737	ANVIL	1	
* 8	335-328	ANVIL	1	FOR EUROPE
9	335-329	HAMMER	1	
10	959-148	STEEL BALL D3.175 (10 PCS.)	28	
11	315-978	WASHER (J)	1	
12	335-316	HAMMER SPRING (J)	1	
13	316-172	WASHER (S)	1	
14	328-647	STOPPER (C)	1	
15	959-154	STEEL BALL D5.556 (10 PCS.)	2	
16	335-318	SPINDLE	1	
17	326-295	IDLE GEAR SET (2 PCS.)	2	
18	319-914	NEEDLE ROLLER	2	
19	333-747	RING GEAR (E)	1	
20	983-852	O-RING (S-42)	1	
21	330-855	WASHER (E)	1	
22	323-118	BALL BEARING 6901VV-N	1	
23	333-952	DAMPER	2	
24	335-317	INNER COVER (E)	1	
25	335-325	ROTOR ASS'Y	1	INCLUD. 26
26	335-723	BALL BEARING 604DD	2	
27	340-852	STATOR FET PCB (C)	1	
28		NAME PLATE	1	
29	313-687	TAPPING SCREW (W/FLANGE) D3 X 16 (BLACK)	9	
30	335-736	HOUSING (A).(B) SET (GREEN)	1	
31	335-722	PANEL SHEET (D)	1	
32	335-724	HOOK	1	
33	327-001	TRUSS HD. SCREW M4 (BLACK)	1	
34	321-661	PUSHING BUTTON (A)	1	
35	335-323	DC-SPEED CONTROL SWITCH	1	
36	335-322	CONTROLLER TERMINAL SET	1	
37	327-002	LOCK NUT M4 (BLACK)	2	
38	306-952	STRAP (BLACK)	1	
39	335-720	WATERPROOF CALK SLEEVE	2	
40	335-324	TERMINAL RUBBER	1	
* 41	334-421	BATTERY BSL 1840 (EUROPE, AUS, NZL)	2	INCLUD. 502
* 41	330-068	BATTERY BSL 1830 (EUROPE, AUS, NZL)	2	INCLUD. 502
* 41	334-728	BATTERY BSL 1830 (CHN)	2	INCLUD. 502
* 41	334-729	BATTERY BSL 1830 (TPE)	2	INCLUD. 502
* 41	334-905	BATTERY BSL 1830 (KOR)	2	INCLUD. 502

STANDARD ACCESSORIES

WH 18DDL

ITEM NO.	CODE NO.	DESCRIPTION	NO. USED	REMARKS
* 501		CHARGER (MODEL UC 18YRSL)	1	
* 501		CHARGER (MODEL UC 18YML2)	1	
502	329-897	BATTERY COVER	1	
503	329-440	CASE ASS'Y	1	INCLUD. 504-507
504	334-233	LATCH (DARK GRAY)	2	
505	334-235	KNOB (L) DARK GRAY	1	
506	334-232	HANDLE (DARK GRAY)	1	
507	334-234	KNOB (R) DARK GRAY	1	

OPTIONAL ACCESSORIES

ITEM NO.	CODE NO.	DESCRIPTION	NO. USED	REMARKS
601	321-823	DRILL CHUCK AND ADAPTER SET	1	INCLUD. 616, 618
602	309-922	GREASE FOR IMPACT DRIVER (500 G)	1	
603	992-671	+ DRIVER BIT (B) NO. 2 50L	1	
604	992-672	+ DRIVER BIT (B) NO. 3 50L	1	
605	996-177	NON-MAGNETIC HEX. SOCKET 8 MM 65L	1	
606	985-329	NON-MAGNETIC HEX. SOCKET 10 MM 65L	1	
607	996-178	NON-MAGNETIC HEX. SOCKET 12 MM 65L	1	
608	996-179	NON-MAGNETIC HEX. SOCKET 13 MM 65L	1	
609	996-180	NON-MAGNETIC HEX. SOCKET 14 MM 65L	1	
610	996-185	NON-MAGNETIC HEX. SOCKET 15 MM 65L	1	
611	996-181	NON-MAGNETIC HEX. SOCKET 16 MM 65L	1	
612	996-182	NON-MAGNETIC HEX. SOCKET 17 MM 65L	1	
613	996-186	NON-MAGNETIC HEX. SOCKET 19 MM 65L	1	
614	996-197	HEX. SOCKET (LONG) 21 MM X 166L	1	
615	996-184	BIT PIECE	1	
616	987-575	CHUCK WRENCH FOR 10VLB-D, 10VLR-D	1	
617	930-119	CHUCK WRENCH 6.5G	1	
618	307-543	CHUCK ADAPTER	1	

